

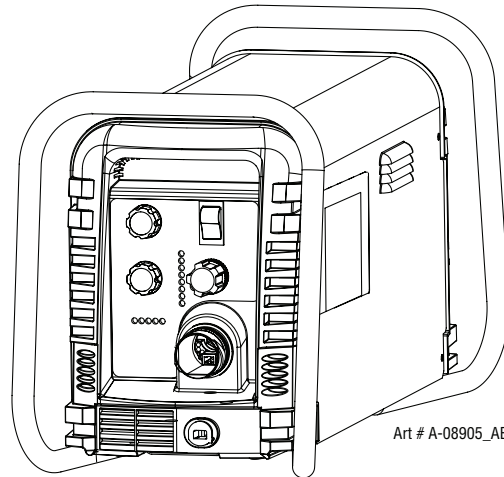

20mm

CUTMASTER™

PLASMA CUTTING SYSTEM



Art # A-08905_AB

Service Manual

Rev. AB

Date: May 29, 2009

Manual # 0-5079

Operating Features:



60
AMP

DC

3
PHASE

380V
400V
415V



WE APPRECIATE YOUR BUSINESS!

Congratulations on your new Thermal Dynamics product. We are proud to have you as our customer and will strive to provide you with the best service and reliability in the industry. This product is backed by our extensive warranty and world-wide service network. To locate your nearest distributor or service agency call 1-800-426-1888, or visit us on the web at www.thermal-dynamics.com.

This Operating Manual has been designed to instruct you on the correct use and operation of your Thermal Dynamics product. Your satisfaction with this product and its safe operation is our ultimate concern. Therefore please take the time to read the entire manual, especially the Safety Precautions. They will help you to avoid potential hazards that may exist when working with this product.

YOU ARE IN GOOD COMPANY!

The Brand of Choice for Contractors and Fabricators Worldwide.

Thermal Dynamics is a Global Brand of manual and automation Plasma Cutting Products for Thermadyne Industries Inc.

We distinguish ourselves from our competition through market-leading, dependable products that have stood the test of time. We pride ourselves on technical innovation, competitive prices, excellent delivery, superior customer service and technical support, together with excellence in sales and marketing expertise.

Above all, we are committed to developing technologically advanced products to achieve a safer working environment within the welding industry.



WARNINGS

Read and understand this entire Manual and your employer's safety practices before installing, operating, or servicing the equipment.

While the information contained in this Manual represents the Manufacturer's best judgement, the Manufacturer assumes no liability for its use.

Plasma Cutting Power Supply
CutMaster™ 20mm
SL60 1Torch™
Service Manual Number 0-5079

Published by:
Thermal Dynamics Corporation
82 Benning Street
West Lebanon, New Hampshire, USA 03784
(603) 298-5711

www.thermal-dynamics.com

Copyright 2009 by
Thermadyne Corporation

All rights reserved.

Reproduction of this work, in whole or in part, without written permission of the publisher is prohibited.

The publisher does not assume and hereby disclaims any liability to any party for any loss or damage caused by any error or omission in this Manual, whether such error results from negligence, accident, or any other cause.

Printed in the United States of America

Original Publication Date: January 9, 2009

Revision Date: May 29, 2009

Record the following information for Warranty purposes:

Where Purchased: _____

Purchase Date: _____

Power Supply Serial #: _____

Torch Serial #: _____

This Page Intentionally Blank

TABLE OF CONTENTS

SECTION 1:GENERAL INFORMATION.....	1
1.01 Notes, Cautions and Warnings	1
1.02 Important Safety Precautions	1
1.03 Publications.....	2
1.04 Note, Attention et Avertissement	3
1.05 Precautions De Securite Importantes.....	3
1.06 Documents De Reference.....	5
1.07 Declaration of Conformity	6
1.08 Statement of Warranty	7
SECTION 2 SYSTEM:INTRODUCTION	2-1
2.01 How To Use This Manual	2-1
2.02 Equipment Identification	2-1
2.03 Receipt Of Equipment.....	2-1
2.04 Power Supply Specifications.....	2-2
2.05 Input Wiring Specifications.....	2-3
2.06 Power Supply Features.....	2-4
SECTION 2 TORCH:INTRODUCTION	2T-1
2T.01 Scope of Manual	2T-1
2T.02 General Description	2T-1
2T.03 Specifications	2T-1
2T.04 Options And Accessories.....	2T-2
2T.05 Introduction to Plasma.....	2T-2
SECTION 3 SYSTEM: INSTALLATION	3-1
3.01 Unpacking	3-1
3.02 Lifting Options.....	3-1
3.03 Primary Input Power Connections	3-2
3.04 Gas Connections	3-4
SECTION 3 TORCH: INSTALLATION	3T-1
3T.01 Torch Connections	3T-1
3T.02 Setting Up Mechanical Torch	3T-1
SECTION 4 SYSTEM: OPERATION	4-1
4.01 Front Panel Controls / Features	4-1
4.02 Preparations for Operation.....	4-2
SECTION 4 TORCH:OPERATION	4T-1
4T.01 Torch Parts Selection.....	4T-1
4T.02 Cut Quality	4T-2
4T.03 General Cutting Information.....	4T-2
4T.04 Hand Torch Operation.....	4T-3
4T.05 Gouging	4T-7
4T.06 Mechanized Torch Operation	4T-8
4T.07 Parts Selection for SL60 Torch Cutting	4T-9
4T.08 Recommended Cutting Speeds for SL60 Torch With Exposed Tip.....	4T-10
4T.09 Recommended Cutting Speeds for SL60 Torch With Shielded Tip.....	4T-13
PATENT INFORMATION	4T-16

TABLE OF CONTENTS

SECTION 5 SYSTEM:SERVICE	5-1
5.01 General Maintenance	5-1
5.02 Maintenance Schedule	5-2
5.03 Common Faults.....	5-2
5.04 Fault Indicator	5-3
5.05 Basic Troubleshooting Guide	5-4
5.06 Power Supply Basic Parts Replacement.....	5-6
5.07 Circuit Fault Isolation	5-8
5.08 Main Input and Internal Power Problems.....	5-12
5.09 Pilot Arc Problems	5-16
5.10 Main Arc and Controls Problems	5-17
5.11 CNC Interface Problems	5-18
5.12 Test Procedures.....	5-18
5.13 Capacitor PCB Layout & Signals	5-22
5.14 Logic PCB Layout & Signals	5-24
5.15 Main PCB Layout & Signals.....	5-28
5.16 Main PCB Wiring Diagram	5-30
SECTION 5 TORCH:SERVICE	5T-1
5T.01 General Maintenance	5T-1
5T.02 Inspection and Replacement of Consumable Torch Parts	5T-2
SECTION 6:PARTS LISTS	6-1
6.01 Introduction	6-1
6.02 Ordering Information.....	6-1
6.03 Power Supply Replacement.....	6-1
6.04 Major External Replacement Parts	6-2
6.05 Front Panel Replacement Parts	6-3
6.06 Left Side Replacement Parts	6-4
6.07 Right Side Replacement Parts	6-5
6.08 Options and Accessories	6-6
6.09 Replacement Parts for Hand Torch	6-7
6.10 Replacement Parts - for Mechanized Torches with Unshielded Leads	6-8
6.11 Torch Consumable Parts Manual and Mechanized Torches	6-10
SECTION 7: REPLACEMENT PROCEDURES	7-1
7.01 Scope.....	7-1
7.02 Anti-Static Handling Procedures.....	7-1
7.03 Parts Replacement - General Information	7-1
7.04 Major External Parts	7-2
7.05 Front Panel Parts Replacement.....	7-3
7.06 Left Side Internal Parts Replacement.....	7-4
7.07 Rear Panel Parts Replacement	7-5
7.08 Right Side Internal Parts Replacement.....	7-7

TABLE OF CONTENTS

APPENDIX 1: SEQUENCE OF OPERATION(BLOCK DIAGRAM)	A-1
APPENDIX 2: DATA TAG INFORMATION	A-2
APPENDIX 3: TORCH PIN - OUT DIAGRAMS	A-3
APPENDIX 4: TORCH CONNECTION DIAGRAMS.....	A-4
APPENDIX 5: SYSTEM SCHEMATIC, 380/400/415V UNITS.....	A-6
APPENDIX 6: Publication History.....	A-8
GLOBAL CUSTOMER SERVICE CONTACT INFORMATION	Inside Rear Cover

TABLE OF CONTENTS

SECTION 1: GENERAL INFORMATION

1.01 Notes, Cautions and Warnings

Throughout this manual, notes, cautions, and warnings are used to highlight important information. These highlights are categorized as follows:

NOTE

An operation, procedure, or background information which requires additional emphasis or is helpful in efficient operation of the system.



CAUTION

A procedure which, if not properly followed, may cause damage to the equipment.



WARNING

A procedure which, if not properly followed, may cause injury to the operator or others in the operating area.

1.02 Important Safety Precautions



WARNINGS

OPERATION AND MAINTENANCE OF PLASMA ARC EQUIPMENT CAN BE DANGEROUS AND HAZARDOUS TO YOUR HEALTH.

Plasma arc cutting produces intense electric and magnetic emissions that may interfere with the proper function of cardiac pacemakers, hearing aids, or other electronic health equipment. Persons who work near plasma arc cutting applications should consult their medical health professional and the manufacturer of the health equipment to determine whether a hazard exists.

To prevent possible injury, read, understand and follow all warnings, safety precautions and instructions before using the equipment. Call 1-603-298-5711 or your local distributor if you have any questions.



GASES AND FUMES

Gases and fumes produced during the plasma cutting process can be dangerous and hazardous to your health.

- Keep all fumes and gases from the breathing area. Keep your head out of the welding fume plume.
- Use an air-supplied respirator if ventilation is not adequate to remove all fumes and gases.

- The kinds of fumes and gases from the plasma arc depend on the kind of metal being used, coatings on the metal, and the differing processes. You must be very careful when cutting or welding any metals which may contain one or more of the following:

Antimony	Chromium	Mercury
Arsenic	Cobalt	Nickel
Barium	Copper	Selenium
Beryllium	Lead	Silver
Cadmium	Manganese	Vanadium

- Always read the Material Safety Data Sheets (MSDS) that should be supplied with the material you are using. These MSDSs will give you the information regarding the kind and amount of fumes and gases that may be dangerous to your health.
- For information on how to test for fumes and gases in your workplace, refer to item 1 in Subsection 1.03, Publications in this manual.
- Use special equipment, such as water or down draft cutting tables, to capture fumes and gases.
- Do not use the plasma torch in an area where combustible or explosive gases or materials are located.
- Phosgene, a toxic gas, is generated from the vapors of chlorinated solvents and cleansers. Remove all sources of these vapors.
- This product, when used for welding or cutting, produces fumes or gases which contain chemicals known to the State of California to cause birth defects and, in some cases, cancer. (California Health & Safety Code Sec. 25249.5 et seq.)



ELECTRIC SHOCK

Electric Shock can injure or kill. The plasma arc process uses and produces high voltage electrical energy. This electric energy can cause severe or fatal shock to the operator or others in the workplace.

- Never touch any parts that are electrically “live” or “hot.”
- Wear dry gloves and clothing. Insulate yourself from the work piece or other parts of the welding circuit.
- Repair or replace all worn or damaged parts.
- Extra care must be taken when the workplace is moist or damp.
- Install and maintain equipment according to NEC code, refer to item 9 in Subsection 1.03, Publications.
- Disconnect power source before performing any service or repairs.
- Read and follow all the instructions in the Operating Manual.



FIRE AND EXPLOSION

Fire and explosion can be caused by hot slag, sparks, or the plasma arc.

- Be sure there is no combustible or flammable material in the workplace. Any material that cannot be removed must be protected.
- Ventilate all flammable or explosive vapors from the workplace.

CUTMASTER 20mm

- Do not cut or weld on containers that may have held combustibles.
- Provide a fire watch when working in an area where fire hazards may exist.
- Hydrogen gas may be formed and trapped under aluminum workpieces when they are cut underwater or while using a water table. **DO NOT** cut aluminum alloys underwater or on a water table unless the hydrogen gas can be eliminated or dissipated. Trapped hydrogen gas that is ignited will cause an explosion.



NOISE

Noise can cause permanent hearing loss. Plasma arc processes can cause noise levels to exceed safe limits. You must protect your ears from loud noise to prevent permanent loss of hearing.

- To protect your hearing from loud noise, wear protective ear plugs and/or ear muffs. Protect others in the workplace.
- Noise levels should be measured to be sure the decibels (sound) do not exceed safe levels.
- For information on how to test for noise, see item 1 in Subsection 1.03, Publications, in this manual.



PLASMA ARC RAYS

Plasma Arc Rays can injure your eyes and burn your skin. The plasma arc process produces very bright ultra violet and infra red light. These arc rays will damage your eyes and burn your skin if you are not properly protected.

- To protect your eyes, always wear a welding helmet or shield. Also always wear safety glasses with side shields, goggles or other protective eye wear.
- Wear welding gloves and suitable clothing to protect your skin from the arc rays and sparks.
- Keep helmet and safety glasses in good condition. Replace lenses when cracked, chipped or dirty.
- Protect others in the work area from the arc rays. Use protective booths, screens or shields.
- Use the shade of lens as suggested in the following per ANSI/ASC Z49.1:

Arc Current	Minimum Protective Shade No.	Suggested Shade No.
Less Than 300*	8	9
300 - 400*	9	12
400 - 800*	10	14

* These values apply where the actual arc is clearly seen. Experience has shown that lighter filters may be used when the arc is hidden by the workpiece.



LEAD WARNING

This product contains chemicals, including lead, or otherwise produces chemicals known to the State of California to cause cancer, birth defects and other reproductive harm. **Wash hands after handling.** (California Health & Safety Code § 25249.5 et seq.)

1.03 Publications

Refer to the following standards or their latest revisions for more information:

1. OSHA, SAFETY AND HEALTH STANDARDS, 29CFR 1910, obtainable from the Superintendent of Documents, U.S. Government Printing Office, Washington, D.C. 20402
2. ANSI Standard Z49.1, SAFETY IN WELDING AND CUTTING, obtainable from the American Welding Society, 550 N.W. LeJeune Rd, Miami, FL 33126
3. NIOSH, SAFETY AND HEALTH IN ARC WELDING AND GAS WELDING AND CUTTING, obtainable from the Superintendent of Documents, U.S. Government Printing Office, Washington, D.C. 20402
4. ANSI Standard Z87.1, SAFE PRACTICES FOR OCCUPATION AND EDUCATIONAL EYE AND FACE PROTECTION, obtainable from American National Standards Institute, 1430 Broadway, New York, NY 10018
5. ANSI Standard Z41.1, STANDARD FOR MEN'S SAFETY-TOE FOOTWEAR, obtainable from the American National Standards Institute, 1430 Broadway, New York, NY 10018
6. ANSI Standard Z49.2, FIRE PREVENTION IN THE USE OF CUTTING AND WELDING PROCESSES, obtainable from American National Standards Institute, 1430 Broadway, New York, NY 10018
7. AWS Standard A6.0, WELDING AND CUTTING CONTAINERS WHICH HAVE HELD COMBUSTIBLES, obtainable from American Welding Society, 550 N.W. LeJeune Rd, Miami, FL 33126
8. NFPA Standard 51, OXYGEN-FUEL GAS SYSTEMS FOR WELDING, CUTTING AND ALLIED PROCESSES, obtainable from the National Fire Protection Association, Batterymarch Park, Quincy, MA 02269
9. NFPA Standard 70, NATIONAL ELECTRICAL CODE, obtainable from the National Fire Protection Association, Batterymarch Park, Quincy, MA 02269
10. NFPA Standard 51B, CUTTING AND WELDING PROCESSES, obtainable from the National Fire Protection Association, Batterymarch Park, Quincy, MA 02269
11. CGA Pamphlet P-1, SAFE HANDLING OF COMPRESSED GASES IN CYLINDERS, obtainable from the Compressed Gas Association, 1235 Jefferson Davis Highway, Suite 501, Arlington, VA 22202
12. CSA Standard W117.2, CODE FOR SAFETY IN WELDING AND CUTTING, obtainable from the Canadian Standards Association, Standards Sales, 178 Rexdale Boulevard, Rexdale, Ontario, Canada M9W 1R3
13. NWSA booklet, WELDING SAFETY BIBLIOGRAPHY obtainable from the National Welding Supply Association, 1900 Arch Street, Philadelphia, PA 19103

14. American Welding Society Standard AWSF4.1, RECOMMENDED SAFE PRACTICES FOR THE PREPARATION FOR WELDING AND CUTTING OF CONTAINERS AND PIPING THAT HAVE HELD HAZARDOUS SUBSTANCES, obtainable from the American Welding Society, 550 N.W. LeJeune Rd, Miami, FL 33126

15. ANSI Standard Z88.2, PRACTICE FOR RESPIRATORY PROTECTION, obtainable from American National Standards Institute, 1430 Broadway, New York, NY 10018

1.04 Note, Attention et Avertissement

Dans ce manuel, les mots “note,” “attention,” et “avertissement” sont utilisés pour mettre en relief des informations à caractère important. Ces mises en relief sont classifiées comme suit :

NOTE

Toute opération, procédure ou renseignement général sur lequel il importe d’insister davantage ou qui contribue à l’efficacité de fonctionnement du système.



ATTENTION

Toute procédure pouvant résulter l’endommagement du matériel en cas de non-respect de la procédure en question.



AVERTISSEMENT

Toute procédure pouvant provoquer des blessures de l’opérateur ou des autres personnes se trouvant dans la zone de travail en cas de non-respect de la procédure en question.

1.05 Precautions De Securite Importantes



AVERTISSEMENTS

L’OPÉRATION ET LA MAINTENANCE DU MATÉRIEL DE SOUDAGE À L’ARC AU JET DE PLASMA PEUVENT PRÉSENTER DES RISQUES ET DES DANGERS DE SANTÉ.

Coupant à l’arc au jet de plasma produit de l’énergie électrique haute tension et des émissions magnétique qui peuvent interférer la fonction propre d’un “pacemaker” cardiaque, les appareils auditif, ou autre matériel de santé électronique. Ceux qui travail près d’une application à l’arc au jet de plasma devrait consulter leur membre professionnel de médication et le manufacturier de matériel de santé pour déterminer s’il existe des risques de santé.

Il faut communiquer aux opérateurs et au personnel TOUS les dangers possibles. Afin d’éviter les blessures possibles, lisez, comprenez et suivez tous les avertissements, toutes les précautions de sécurité et toutes les consignes avant d’utiliser le matériel. Composez le + 603-298-5711 ou votre distributeur local si vous avez des questions.



FUMÉE et GAZ

La fumée et les gaz produits par le procédé de jet de plasma peuvent présenter des risques et des dangers de santé.

- Eloignez toute fumée et gaz de votre zone de respiration. Gardez votre tête hors de la plume de fumée provenant du chalumeau.
- Utilisez un appareil respiratoire à alimentation en air si l’aération fournie ne permet pas d’éliminer la fumée et les gaz.
- Les sortes de gaz et de fumée provenant de l’arc de plasma dépendent du genre de métal utilisé, des revêtements se trouvant sur le métal et des différents procédés. Vous devez prendre soin lorsque vous coupez ou soudez tout métal pouvant contenir un ou plusieurs des éléments suivants:

antimoine	cadmium	mercure
argent	chrome	nickel
arsenic	cobalt	plomb
baryum	cuivre	sélénium
béryllium	manganèse	vanadium

- Lisez toujours les fiches de données sur la sécurité des matières (sigle américain “MSDS”); celles-ci devraient être fournies avec le matériel que vous utilisez. Les MSDS contiennent des renseignements quant à la quantité et la nature de la fumée et des gaz pouvant poser des dangers de santé.
- Pour des informations sur la manière de tester la fumée et les gaz de votre lieu de travail, consultez l’article 1 et les documents cités à la page 5.
- Utilisez un équipement spécial tel que des tables de coupe à débit d’eau ou à courant descendant pour capter la fumée et les gaz.
- N’utilisez pas le chalumeau au jet de plasma dans une zone où se trouvent des matières ou des gaz combustibles ou explosifs.
- Le phosgène, un gaz toxique, est généré par la fumée provenant des solvants et des produits de nettoyage chlorés. Éliminez toute source de telle fumée.
- Ce produit, dans le procédé de soudage et de coupe, produit de la fumée ou des gaz pouvant contenir des éléments reconnu dans L’état de la Californie, qui peuvent causer des défauts de naissance et le cancer. (La sécurité de santé en Californie et la code sécurité Sec. 25249.5 et seq.)



CHOC ELECTRIQUE

Les chocs électriques peuvent blesser ou même tuer. Le procédé au jet de plasma requiert et produit de l’énergie électrique haute tension. Cette énergie électrique peut produire des chocs graves, voire mortels, pour l’opérateur et les autres personnes sur le lieu de travail.

- Ne touchez jamais une pièce “sous tension” ou “vive”; portez des gants et des vêtements secs. Isolez-vous de la pièce de travail ou des autres parties du circuit de soudage.
- Réparez ou remplacez toute pièce usée ou endommagée.
- Prenez des soins particuliers lorsque la zone de travail est humide ou moite.

CUTMASTER 20mm

- Montez et maintenez le matériel conformément au Code électrique national des Etats-Unis. (Voir la page 5, article 9.)
- Débranchez l'alimentation électrique avant tout travail d'entretien ou de réparation.
- Lisez et respectez toutes les consignes du Manuel de consignes.



INCENDIE ET EXPLOSION

Les incendies et les explosions peuvent résulter des scories chaudes, des étincelles ou de l'arc de plasma. Le procédé à l'arc de plasma produit du métal, des étincelles, des scories chaudes pouvant mettre le feu aux matières combustibles ou provoquer l'explosion de fumées inflammables.

- Soyez certain qu'aucune matière combustible ou inflammable ne se trouve sur le lieu de travail. Protégez toute telle matière qu'il est impossible de retirer de la zone de travail.
- Procurez une bonne aération de toutes les fumées inflammables ou explosives.
- Ne coupez pas et ne soudez pas les conteneurs ayant pu renfermer des matières combustibles.
- Prévoyez une veille d'incendie lors de tout travail dans une zone présentant des dangers d'incendie.
- Le gas hydrogène peut se former ou s'accumuler sous les pièces de travail en aluminium lorsqu'elles sont coupées sous l'eau ou sur une table d'eau. NE PAS couper les alliages en aluminium sous l'eau ou sur une table d'eau à moins que le gas hydrogène peut s'échapper ou se dissiper. Le gas hydrogène accumulé explosera si enflammé.



RAYONS D'ARC DE PLASMA

Les rayons provenant de l'arc de plasma peuvent blesser vos yeux et brûler votre peau. Le procédé à l'arc de plasma produit une lumière infra-rouge et des rayons ultra-violet très forts. Ces rayons d'arc nuiront à vos yeux et brûleront votre peau si vous ne vous protégez pas correctement.

- Pour protéger vos yeux, portez toujours un casque ou un écran de soudeur. Portez toujours des lunettes de sécurité munies de parois latérales ou des lunettes de protection ou une autre sorte de protection oculaire.
- Portez des gants de soudeur et un vêtement protecteur approprié pour protéger votre peau contre les étincelles et les rayons de l'arc.
- Maintenez votre casque et vos lunettes de protection en bon état. Remplacez toute lentille sale ou comportant fissure ou rognure.
- Protégez les autres personnes se trouvant sur la zone de travail contre les rayons de l'arc en fournissant des cabines ou des écrans de protection.

- Utilisez la nuance de lentille qui est suggérée dans la recommandation qui suivent ANSI/ASC Z49.1:

Courant Arc	Nuance Minimum Protective Numéro	Nuance Suggestée Numéro
Moins de 300*	8	9
300 - 400*	9	12
400 - 800*	10	14

* Ces valeurs s'appliquent ou l'arc actuel est observé clairement. L'expérience a démontré que les filtres moins foncés peuvent être utilisés quand l'arc est caché par moiceau de travail.



BRUIT

Le bruit peut provoquer une perte permanente de l'ouïe. Les procédés de soudage à l'arc de plasma peuvent provoquer des niveaux sonores supérieurs aux limites normalement acceptables. Vous devez vous protéger les oreilles contre les bruits forts afin d'éviter une perte permanente de l'ouïe.

- Pour protéger votre ouïe contre les bruits forts, portez des tampons protecteurs et/ou des protections auriculaires. Protégez également les autres personnes se trouvant sur le lieu de travail.
- Il faut mesurer les niveaux sonores afin d'assurer que les décibels (le bruit) ne dépassent pas les niveaux sûrs.
- Pour des renseignements sur la manière de tester le bruit, consultez l'article 1, page 5.



PLOMB AVERTISSEMENT

Ce produit contient des produits chimiques, comme le plomb, ou engendre des produits chimiques, reconnus par l'état de Californie comme pouvant être à l'origine de cancer, de malformations fœtales ou d'autres problèmes de reproduction. **Il faut se laver les mains après toute manipulation.** (Code de Californie de la sécurité et santé, paragraphe 25249.5 et suivants)

1.06 Documents De Reference

Consultez les normes suivantes ou les révisions les plus récentes ayant été faites à celles-ci pour de plus amples renseignements :

1. OSHA, NORMES DE SÉCURITÉ DU TRAVAIL ET DE PROTECTION DE LA SANTÉ, 29CFR 1910, disponible auprès du Superintendent of Documents, U.S. Government Printing Office, Washington, D.C. 20402
2. Norme ANSI Z49.1, LA SÉCURITÉ DES OPÉRATIONS DE COUPE ET DE SOUDAGE, disponible auprès de la Société Américaine de Soudage (American Welding Society), 550 N.W. LeJeune Rd., Miami, FL 33126
3. NIOSH, LA SÉCURITÉ ET LA SANTÉ LORS DES OPÉRATIONS DE COUPE ET DE SOUDAGE À L'ARC ET AU GAZ, disponible auprès du Superintendent of Documents, U.S. Government Printing Office, Washington, D.C. 20402
4. Norme ANSI Z87.1, PRATIQUES SURES POUR LA PROTECTION DES YEUX ET DU VISAGE AU TRAVAIL ET DANS LES ECOLES, disponible de l'Institut Américain des Normes Nationales (American National Standards Institute), 1430 Broadway, New York, NY 10018
5. Norme ANSI Z41.1, NORMES POUR LES CHAUSSURES PROTECTRICES, disponible auprès de l'American National Standards Institute, 1430 Broadway, New York, NY 10018
6. Norme ANSI Z49.2, PRÉVENTION DES INCENDIES LORS DE L'EMPLOI DE PROCÉDÉS DE COUPE ET DE SOUDAGE, disponible auprès de l'American National Standards Institute, 1430 Broadway, New York, NY 10018
7. Norme A6.0 de l'Association Américaine du Soudage (AWS), LE SOUDAGE ET LA COUPE DE CONTENEURS AYANT RENFERMÉ DES PRODUITS COMBUSTIBLES, disponible auprès de la American Welding Society, 550 N.W. LeJeune Rd., Miami, FL 33126
8. Norme 51 de l'Association Américaine pour la Protection contre les Incendies (NFPA), LES SYSTEMES À GAZ AVEC ALIMENTATION EN OXYGENE POUR LE SOUDAGE, LA COUPE ET LES PROCÉDÉS ASSOCIÉS, disponible auprès de la National Fire Protection Association, Batterymarch Park, Quincy, MA 02269
9. Norme 70 de la NFPA, CODE ELECTRIQUE NATIONAL, disponible auprès de la National Fire Protection Association, Batterymarch Park, Quincy, MA 02269
10. Norme 51B de la NFPA, LES PROCÉDÉS DE COUPE ET DE SOUDAGE, disponible auprès de la National Fire Protection Association, Batterymarch Park, Quincy, MA 02269
11. Brochure GCA P-1, LA MANIPULATION SANS RISQUE DES GAZ COMPRIMÉS EN CYLINDRES, disponible auprès de l'Association des Gaz Comprimés (Compressed Gas Association), 1235 Jefferson Davis Highway, Suite 501, Arlington, VA 22202
12. Norme CSA W117.2, CODE DE SÉCURITÉ POUR LE SOUDAGE ET LA COUPE, disponible auprès de l'Association des Normes Canadiennes, Standards Sales, 178 Rexdale Boulevard, Rexdale, Ontario, Canada, M9W 1R3
13. Livret NWSA, BIBLIOGRAPHIE SUR LA SÉCURITÉ DU SOUDAGE, disponible auprès de l'Association Nationale de Fournitures de Soudage (National Welding Supply Association), 1900 Arch Street, Philadelphia, PA 19103
14. Norme AWSF4.1 de l'Association Américaine de Soudage, RECOMMANDATIONS DE PRATIQUES SURES POUR LA PRÉPARATION À LA COUPE ET AU SOUDAGE DE CONTENEURS ET TUYAUX AYANT RENFERMÉ DES PRODUITS DANGEREUX , disponible auprès de la American Welding Society, 550 N.W. LeJeune Rd., Miami, FL 33126
15. Norme ANSI Z88.2, PRATIQUES DE PROTECTION RESPIRATOIRE, disponible auprès de l'American National Standards Institute, 1430 Broadway, New York, NY 10018

CUTMASTER 20mm

1.07 Declaration of Conformity

Manufacturer: Thermal Dynamics Corporation
Address: 82 Benning Street
West Lebanon, New Hampshire 03784
USA

The equipment described in this manual conforms to all applicable aspects and regulations of the 'Low Voltage Directive' (2006/95 EC) and to the National legislation for the enforcement of this Directive.

The equipment described in this manual conforms to all applicable aspects and regulations of the "EMC Directive" (European Council Directive 89/336/EEC) and to the National legislation for the enforcement of this Directive.

Serial numbers are unique with each individual piece of equipment and details description, parts used to manufacture a unit and date of manufacture.

National Standard and Technical Specifications

The product is designed and manufactured to a number of standards and technical requirements. Among them are:

- * CSA (Canadian Standards Association) standard C22.2 number 60 for Arc welding equipment.
- * UL (Underwriters Laboratory) rating 94VO flammability testing for all printed-circuit boards used.
- * CENELEC EN50199 EMC Product Standard for Arc Welding Equipment.
- * ISO/IEC 60974-1 (BS 638-PT10) (EN 60 974-1) (EN50192) (EN50078) applicable to plasma cutting equipment and associated accessories.
- * For environments with increased hazard of electrical shock, Power Supplies bearing the 'S' mark conform to EN50192 when used in conjunction with hand torches with exposed cutting tips, if equipped with properly installed standoff guides.
- * Extensive product design verification is conducted at the manufacturing facility as part of the routine design and manufacturing process. This is to ensure the product is safe, when used according to instructions in this manual and related industry standards, and performs as specified. Rigorous testing is incorporated into the manufacturing process to ensure the manufactured product meets or exceeds all design specifications.

Thermal Dynamics has been manufacturing products for more than 30 years, and will continue to achieve excellence in our area of manufacture.

Manufacturers responsible representative: Steve Ward
Operations Director
Thermadyne Europe
Europa Building
Chorley N Industrial Park
Chorley, Lancashire,
England PR6 7BX



1.08 Statement of Warranty

LIMITED WARRANTY: Subject to the terms and conditions established below, Thermal Dynamics® Corporation warrants to the original retail purchaser that new Thermal Dynamics CUTMASTER™ 1Series plasma cutting systems sold after the effective date of this warranty are free of defects in material and workmanship. Should any failure to conform to this warranty appear within the applicable period stated below, Thermal Dynamics Corporation shall, upon notification thereof and substantiation that the product has been stored operated and maintained in accordance with Thermal Dynamics' specifications, instructions, recommendations and recognized industry practice, correct such defects by suitable repair or replacement.

This warranty is exclusive and in lieu of any warranty of merchantability or fitness for a particular purpose.

Thermal Dynamics will repair or replace, at its discretion, any warranted parts or components that fail due to defects in material or workmanship within the time periods set out below. Thermal Dynamics Corporation must be notified within 30 days of any failure, at which time Thermal Dynamics Corporation will provide instructions on the warranty procedures to be implemented.

Thermal Dynamics Corporation will honor warranty claims submitted within the warranty periods listed below. All warranty periods begin on the date of sale of the product to the original retail customer or 1 year after sale to an authorized Thermal Dynamics Distributor.

LIMITED WARRANTY PERIOD

Product	Power Supply Components (Parts and Labor)	Torch and Leads (Parts and Labor)
CUTMASTER™ 10mm	3 Years	1 Year
CUTMASTER™ 12mm	3 Years	1 Year
CUTMASTER™ 20mm	3 Years	1 Year
CUTMASTER™ 25mm	3 Years	1 Year
CUTMASTER™ 35mm	3 Years	1 Year
CUTMASTER™ 40mm	3 Years	1 Year

This warranty does not apply to:

1. Consumable Parts, such as tips, electrodes, shield cups, o - rings, starter cartridges, gas distributors, fuses, filters.
2. Equipment that has been modified by an unauthorized party, improperly installed, improperly operated or misused based upon industry standards.

In the event of a claim under this warranty, the remedies shall be, at the discretion of Thermal Dynamics Corporation:

1. Repair of the defective product.
2. Replacement of the defective product.
3. Reimbursement of reasonable costs of repair when authorized in advance by Thermal Dynamics.
4. Payment of credit up to the purchase price less reasonable depreciation based on actual use.

These remedies may be authorized by Thermal Dynamics and are FOB West Lebanon, NH or an authorized Thermadyne service station. Product returned for service is at the owner's expense and no reimbursement of travel or transportation is authorized.

LIMITATION OF LIABILITY: Thermal Dynamics Corporation shall not under any circumstances be liable for special or consequential damages such as, but not limited to, damage or loss of purchased or replacement goods or claims of customer or distributors (hereinafter "Purchaser") for service interruption. The remedies of the Purchaser set forth herein are exclusive and the liability of Thermal Dynamics with respect to any contract, or anything done in connection therewith such as the performance or breach thereof, or from the manufacture, sale, delivery, resale, or use of the goods covered by or furnished by Thermal Dynamics whether arising out of contract, negligence, strict tort, or under any warranty, or otherwise, shall not, except as expressly provided herein, exceed the price of the goods upon which liability is based.

This warranty becomes invalid if replacement parts or accessories are used which may impair the safety or performance of any Thermal Dynamics product.

This warranty is invalid if the Thermal Dynamics product is sold by non - authorized persons.

Effective September 4, 2007

This Page Intentionally Blank

SECTION 2 SYSTEM: INTRODUCTION

2.01 How To Use This Manual

This Service Manual applies to just specification or part numbers listed on page i.

To ensure safe operation, read the entire manual, including the chapter on safety instructions and warnings.

Throughout this manual, the words **WARNING**, **CAUTION**, and **NOTE** may appear. Pay particular attention to the information provided under these headings. These special annotations are easily recognized as follows:



WARNING

A WARNING gives information regarding possible personal injury.



CAUTION

A CAUTION refers to possible equipment damage.

NOTE

A NOTE offers helpful information concerning certain operating procedures.

Additional copies of this manual may be purchased by contacting Thermadyne at the address and phone number in your area listed in the inside back cover of this manual. Include the Service Manual number and equipment identification numbers.

Electronic copies of this manual can also be downloaded at no charge in Acrobat PDF format by going to the

Thermal Dynamics web site listed below and clicking on Thermal Dynamics and then on the Literature link:

<http://www.thermal-dynamics.com>

2.02 Equipment Identification

The unit's identification number (specification or part number), model, and serial number usually appear on a data tag attached to the rear panel. Equipment which does not have a data tag such as torch and cable assemblies are identified only by the specification or part number printed on loosely attached card or the shipping container. Record these numbers on the bottom of page 1 for future reference.

2.03 Receipt Of Equipment

When you receive the equipment, check it against the invoice to make sure it is complete and inspect the equipment for possible damage due to shipping. If there is any damage, notify the carrier immediately to file a claim. Furnish complete information concerning damage claims or shipping errors to the location in your area listed in the inside back cover of this manual.

Include all equipment identification numbers as described above along with a full description of the parts in error.

Move the equipment to the installation site before un-crating the unit. Use care to avoid damaging the equipment when using bars, hammers, etc., to un-crate the unit.

CUTMASTER 20mm

2.04 Power Supply Specifications

CutMaster 20mm Power Supply Specifications				
Input Power	380 VAC (360 - 440 VAC), Three Phase, 50/60 Hz			
	400/415 VAC (360 - 440 VAC), Three Phase, 50/60 Hz			
Input Power Cable	Power Supply includes input cable. Cable for 380/400/415V 3Phase.			
Output Current	20 - 60 Amps, Continuously Adjustable			
Power Supply Gas Filtering Ability	Particulates to 5 Microns			
CutMaster 20mm Power Supply Duty Cycle *				
Ambient Temperature	Duty Cycle Ratings @ 40° C (104° F) Operating Range 0° - 50° C			
		IEC Rating	IEC Rating	IEC Rating
All Units	Duty Cycle	40%	60%	100%
	Current	60 Amps	50 Amps	30 Amps
	DC Voltage	104	102	100
* NOTE: The duty cycle will be reduced if the primary input power (AC) is low or the output voltage (DC) is higher than shown in this chart.				

NOTE

IEC Rating is determined as specified by the International Electro-Technical Commission. These specifications include calculating an output voltage based upon power supply rated current. To facilitate comparison between power supplies, all manufacturers use this output voltage to determine duty cycle.

Power Supply Dimensions & Weight

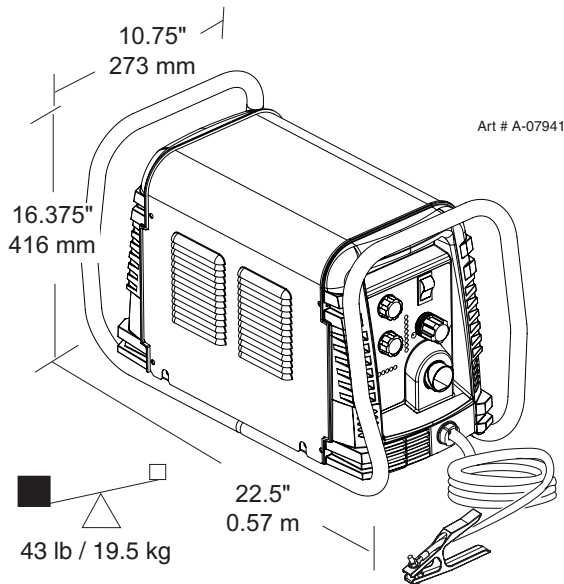

Ventilation Clearance Requirements

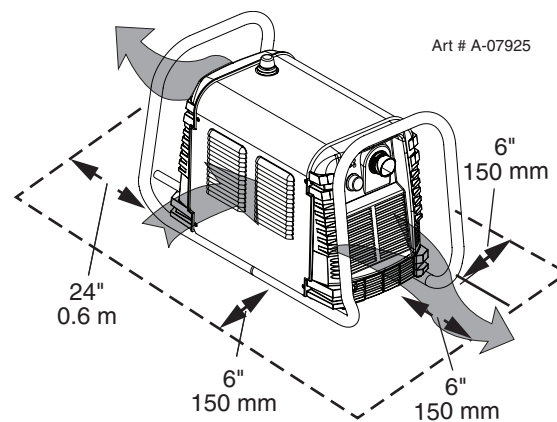

2.05 Input Wiring Specifications

CutMaster 20mm Power Supply Input Cable Wiring Requirements							
	Input voltage	Freq	Power Input			Suggested Sizes	
	Volts	Hz	kVA	I max	I eff	Fuse (amps)	Flexible Cord (Min. AWG)
3 Phase	380	50/60	11	16	11	20	14
	400/415	50/60	11	16	11	20	14
Line Voltages with Suggested Circuit Protection and Wire Sizes Based on National Electric Code and Canadian Electric Code							

NOTES

Refer to Local and National Codes or local authority having jurisdiction for proper wiring requirements.

Cable size is de-rated based on the Duty Cycle of the equipment.

2.06 Power Supply Features

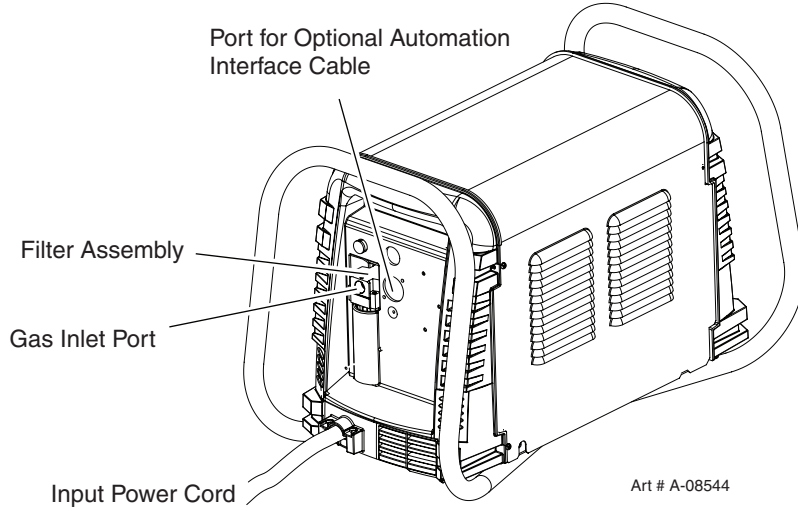
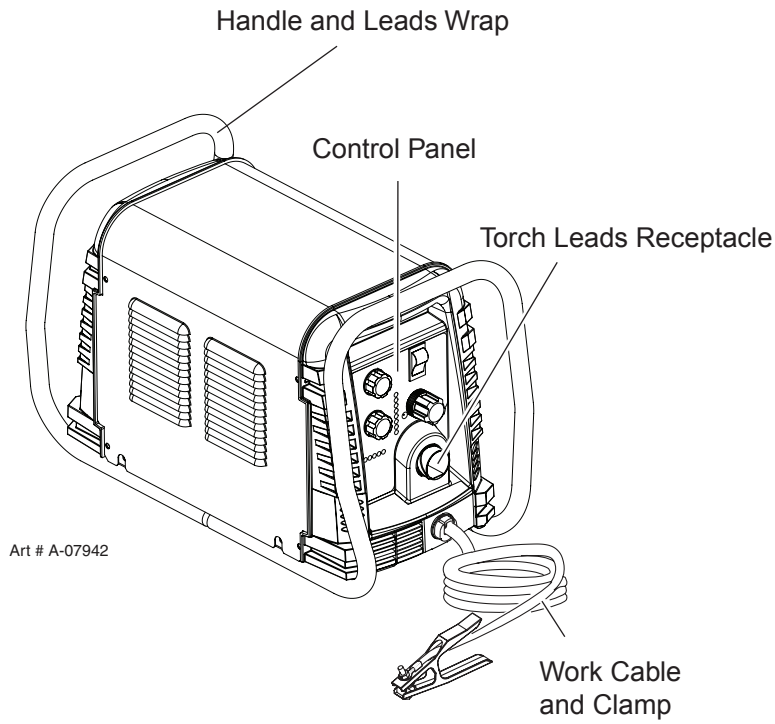

SECTION 2 TORCH: INTRODUCTION

2T.01 Scope of Manual

This manual contains descriptions, operating instructions and maintenance procedures for the 1 Torch Models SL60/Manual and SL100/Mechanized Plasma Cutting Torches. Service of this equipment is restricted to properly trained personnel; unqualified personnel are strictly cautioned against attempting repairs or adjustments not covered in this manual, at the risk of voiding the Warranty.

Read this manual thoroughly. A complete understanding of the characteristics and capabilities of this equipment will assure the dependable operation for which it was designed.

2T.02 General Description

Plasma torches are similar in design to the automotive spark plug. They consist of negative and positive sections separated by a center insulator. Inside the torch, the pilot arc starts in the gap between the negatively charged electrode and the positively charged tip. Once the pilot arc has ionized the plasma gas, the superheated column of gas flows through the small orifice in the torch tip, which is focused on the metal to be cut.

A single torch lead provides gas from a single source to be used as both the plasma and secondary gas. The air flow is divided inside the torch head. Single - gas operation provides a smaller sized torch and inexpensive operation.

NOTE

Refer to Section 2T.05, Introduction To Plasma, for a more detailed description of plasma torch operation.

Refer to the Appendix Pages for additional specifications as related to the Power Supply used.

2T.03 Specifications

A. Torch Configurations

1. Hand/Manual Torch, Models

The hand torch head is at 75° to the torch handle. The hand torches include a torch handle and torch trigger assembly.

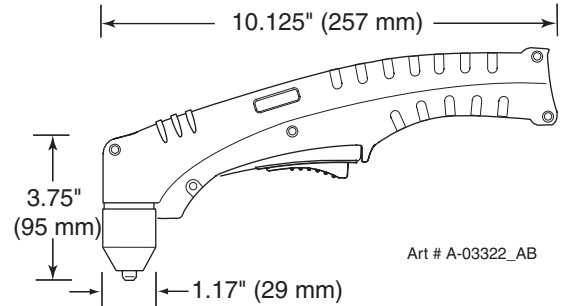

2. Mechanized Torch, Model

The standard machine torch has a positioning tube with rack & pinch block assembly.

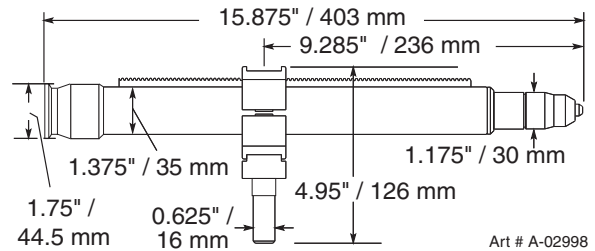

B. Torch Leads Lengths

Hand Torches are available as follows:

- 20 ft / 6.1 m, with ATC connectors
- 50 ft / 15.2 m, with ATC connectors

Machine Torches are available as follows:

- 5 foot / 1.5 m, with ATC connectors
- 10 foot / 3.05 m, with ATC connectors
- 25 foot / 7.6 m, with ATC connectors
- 50 foot / 15.2 m, with ATC connectors

C. Torch Parts

Starter Cartridge, Electrode, Tip, Shield Cup

D. Parts - In - Place (PIP)

Torch Head has built - in switch

12 vdc circuit rating

E. Type Cooling

Combination of ambient air and gas stream through torch.

CUTMASTER 20mm

F. Torch Ratings

Manual Torch Ratings	
Ambient Temperature	104° F 40° C
Duty Cycle	100% @ 60 Amps @ 400 scfh
Maximum Current	80 Amps
Voltage (V _{peak})	500V
Arc Striking Voltage	7kV

Mechanized Torch Ratings	
Ambient Temperature	104° F 40° C
Duty Cycle	100% @ 100 Amps @ 400 scfh
Maximum Current	120 Amps
Voltage (V _{peak})	500V
Arc Striking Voltage	7kV

G. Gas Requirements

Manual and Mechanized Torch Gas Specifications	
Gas (Plasma and Secondary)	Compressed Air
Operating Pressure <i>Refer to NOTE</i>	60 - 95 psi 4.1 - 6.5 bar
Maximum Input Pressure	125 psi / 8.6 bar
Gas Flow (Cutting and Gouging)	300 - 500 scfh 142 - 235 lpm



WARNING

This torch is not to be used with oxygen (O₂).

NOTE

Operating pressure varies with torch model, operating amperage, and torch leads length. Refer to gas pressure settings charts for each model.

H. Direct Contact Hazard

For standoff tip the recommended standoff is 3/16 inches / 4.7 mm.

2T.04 Options And Accessories

For options and accessories, see section 6.

2T.05 Introduction to Plasma

A. Plasma Gas Flow

Plasma is a gas which has been heated to an extremely high temperature and ionized so that it becomes electrically conductive. The plasma arc cutting and gouging processes use this plasma to transfer an electrical arc to the workpiece. The metal to be cut or removed is melted by the heat of the arc and then blown away.

While the goal of plasma arc cutting is separation of the material, plasma arc gouging is used to remove metals to a controlled depth and width.

In a Plasma Cutting Torch a cool gas enters Zone B, where a pilot arc between the electrode and the torch tip heats and ionizes the gas. The main cutting arc then transfers to the workpiece through the column of plasma gas in Zone C.

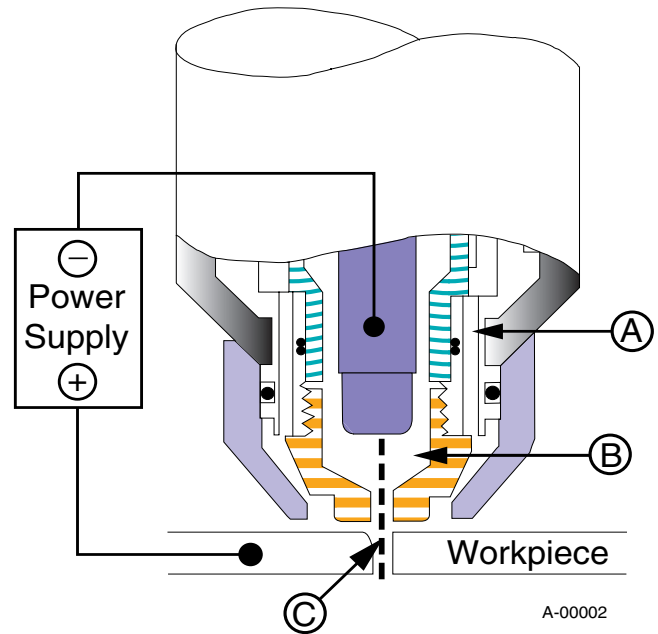

Typical Torch Head Detail

By forcing the plasma gas and electric arc through a small orifice, the torch delivers a high concentration of heat to a small area. The stiff, constricted plasma arc is shown in Zone C. Direct current (DC) straight polarity is used for plasma cutting, as shown in the illustration.

Zone A channels a secondary gas that cools the torch. This gas also assists the high velocity plasma gas in blowing the molten metal out of the cut allowing for a fast, slag - free cut.

B. Gas Distribution

The single gas used is internally split into plasma and secondary gases.

The plasma gas flows into the torch through the negative lead, through the starter cartridge, around the electrode, and out through the tip orifice.

The secondary gas flows down around the outside of the torch starter cartridge, and out between the tip and shield cup around the plasma arc.

C. Pilot Arc

When the torch is started a pilot arc is established between the electrode and cutting tip. This pilot arc creates a path for the main arc to transfer to the work.

D. Main Cutting Arc

DC power is also used for the main cutting arc. The negative output is connected to the torch electrode through the torch lead. The positive output is connected to the workpiece via the work cable and to the torch through a pilot wire.

E. Parts - In - Place (PIP)

The torch includes a 'Parts - In - Place' (PIP) circuit. When the shield cup is properly installed, it closes a switch. The torch will not operate if this switch is open.

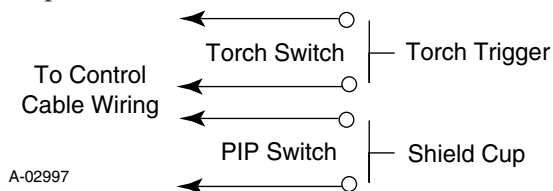

Parts - In - Place Circuit Diagram for Hand Torch

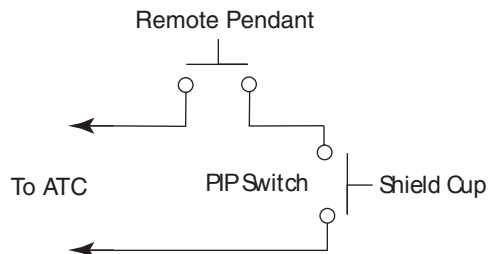

CNC Start

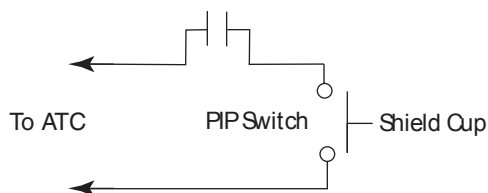

Parts - In - Place Circuit Diagram for Machine Torch

Art # A-08168

This Page Intentionally Blank

SECTION 3 SYSTEM: INSTALLATION

3.01 Unpacking

1. Use the packing lists to identify and account for each item.
2. Inspect each item for possible shipping damage. If damage is evident, contact your distributor and / or shipping company before proceeding with the installation.
3. Record Power Supply and Torch model and serial numbers, purchase date and vendor name, in the information block at the front of this manual.

3.02 Lifting Options

The Power Supply includes a handle for **hand lifting only**. Be sure unit is lifted and transported safely and securely.



WARNING

Do not touch live electrical parts.

Disconnect input power cord before moving unit.

***FALLING EQUIPMENT** can cause serious personal injury and can damage equipment.*

***HANDLE** is not for mechanical lifting.*

- Only persons of adequate physical strength should lift the unit.
- Lift unit by the handles, using two hands. Do not use straps for lifting.
- Use optional cart or similar device of adequate capacity to move unit.
- Place unit on a proper skid and secure in place before transporting with a fork lift or other vehicle.

3.03 Primary Input Power Connections



Check your power source for correct voltage before plugging in or connecting the unit. The primary power source, fuse, and any extension cords used must conform to local electrical code and the recommended circuit protection and wiring requirements as specified in Section 2.

Connections for Three Phase Input Power



Disconnect input power from the power supply and input cable before attempting this procedure.

These instructions are for installing the input power cable to the power supply and connecting to 380/400/415VAC three phase Primary Input Power.

1. Remove the Power Supply cover per instructions found in section 5.
2. Loosen the strain relief on the back panel of the power supply.
3. Using a customer supplied four conductor input power cable for rated voltage, strip back the insulation on the individual wires.
4. Pass the cable being used through the input cable opening / strain relief in the back panel of the power supply. Refer to Section 2 for power cable specifications.



The primary power source and power cable must conform to local electrical code and the recommended circuit protection and wiring requirements (refer to table in Section 2).

5. Connect the wires as follows.
For non CE units:

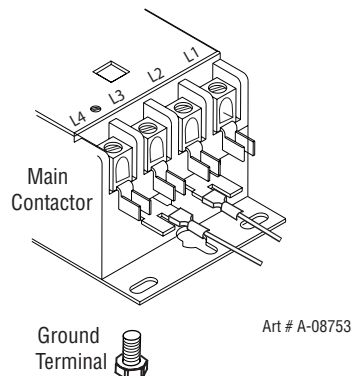

- Three phase wires to L1, L2 and L3 on the W1 contactor. It does not matter what order these wires are attached. See previous illustration and on label in the power supply.
- Green / Yellow wire to Ground Terminal.

For CE units:

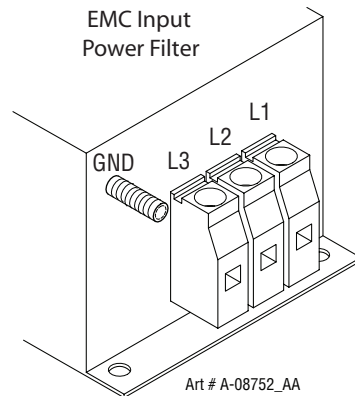

- Three phase wires to L1, L2 and L3 on the CE Input Power Filter. It does not matter what order these wires are attached. See previous illustration and on label in the power supply.
 - Green / Yellow wire to Ground.
6. With a little slack in the wires, tighten the strain relief to secure the power cable.
 7. Reinstall the Power Supply cover.
 8. Connect the opposite end of individual wires to a customer supplied plug and plug into an appropriate input power receptacle.(or connect directly to main disconnect)
 9. Close the main disconnect switch to supply power to the unit..

3.04 Gas Connections

Connecting Gas Supply to Unit

The connection is the same for compressed air or high pressure cylinders. Refer to the following two subsections if an optional air line filter is to be installed.

1. Connect the air line to the inlet port. The illustration shows typical fittings as an example.

NOTE

For a secure seal, apply thread sealant to the fitting threads, according to manufacturer's instructions. Do not use Teflon tape as a thread sealer, as small particles of the tape may break off and block the small air passages in the torch.

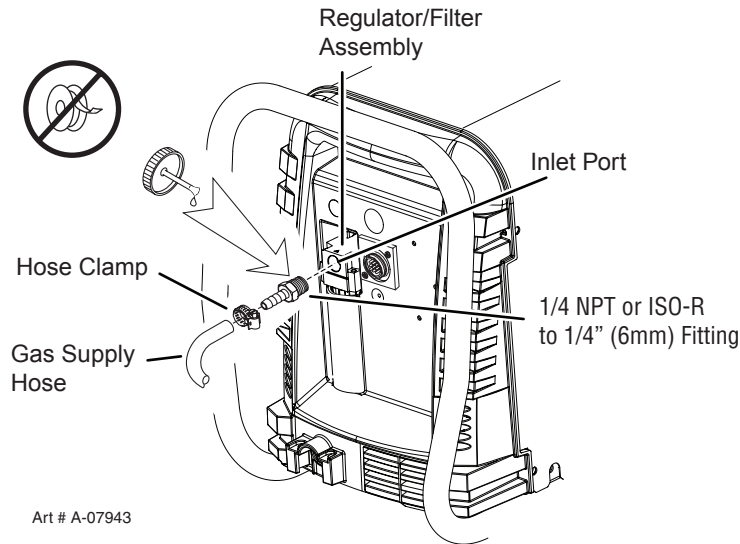

Air Connection to Inlet Port

Installing Optional Single - Stage Air Filter

An optional filter kit is recommended for improved filtering with compressed air, to keep moisture and debris out of the torch.

1. Attach the Single - Stage Filter Hose to the Inlet Port.
2. Attach the Filter Assembly to the filter hose.
3. Connect the air line to the Filter. The illustration shows typical fittings as an example.

NOTE

For a secure seal, apply thread sealant to the fitting threads, according to the maker's instructions. Do Not use Teflon tape as a thread sealer, as small particles of the tape may break off and block the small air passages in the torch. Connect as follows:

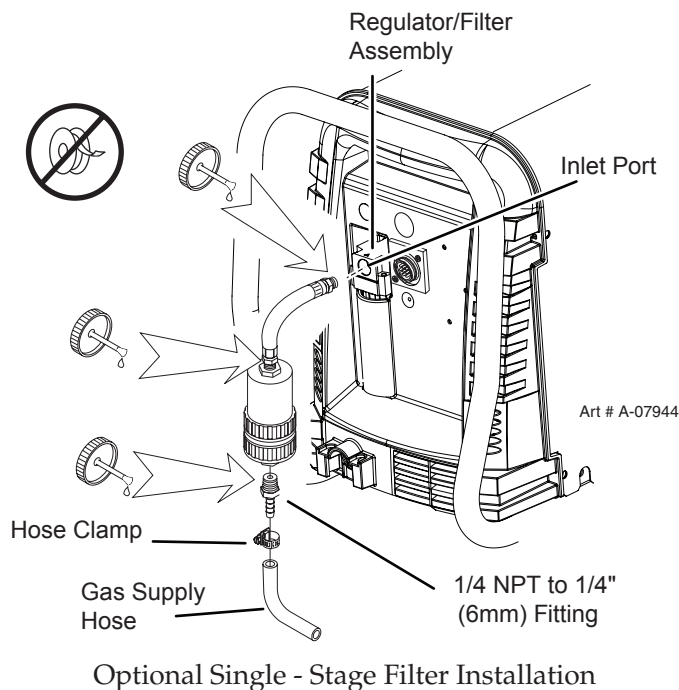

CUTMASTER 20mm

Installing Optional Two - Stage Air Filter Kit

This optional two - stage air line filter is also for use on compressed air shop systems. Filter removes moisture and contaminants to at least 5 microns.

Connect the air supply as follows:

1. Attach the Two Stage Filter bracket to the back of the power supply per instructions supplied with the filter assembly.

NOTE

For a secure seal, apply thread sealant to the fitting threads according to manufacturer's instructions. Do Not use Teflon tape as a thread sealer as small particles of the tape may break off and block the small air passages in the torch.

2. Connect the two stage filter outlet hose to the inlet port of the Regulator / Filter Assembly.
3. Use customer - supplied fittings to connect the air line to the Filter. A 1/4 NPT to 1/4" hose barbed fitting is shown as an example.

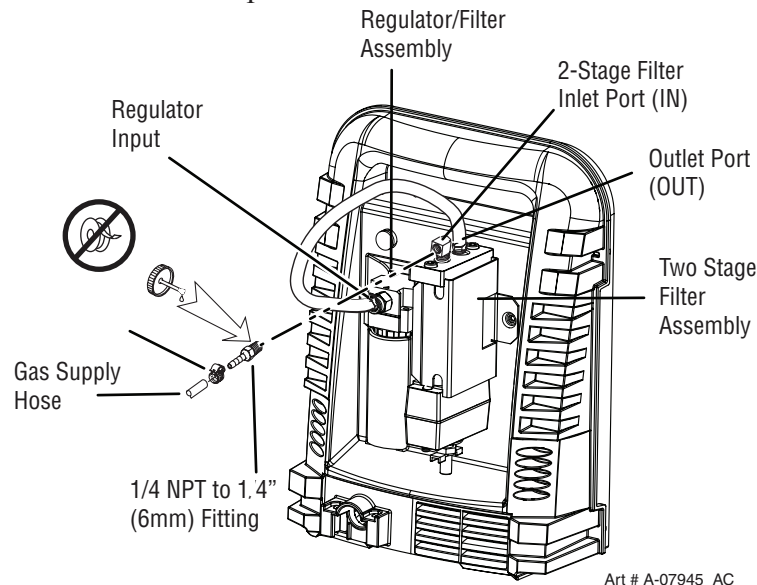

Optional Two - Stage Filter Installation

Using High Pressure Air Cylinders

When using high pressure air cylinders as the air supply:

1. Refer to the manufacturer's specifications for installation and maintenance procedures for high pressure regulators.
2. Examine the cylinder valves to be sure they are clean and free of oil, grease or any foreign material. Briefly open each cylinder valve to blow out any dust which may be present.
3. The cylinder must be equipped with an adjustable high - pressure regulator capable of outlet pressures up to 100 psi (6.9 bar) maximum and flows of at least 300 scfh (141.5 lpm).
4. Connect supply hose to the cylinder.

NOTE

Pressure should be set at 100 psi (6.9 bar) at the high pressure cylinder regulator.

Supply hose must be at least 1/4 inch (6 mm) I.D.

For a secure seal, apply thread sealant to the fitting threads, according to manufacturer's instructions. Do Not use Teflon tape as a thread sealer, as small particles of the tape may break off and block the small air passages in the torch

SECTION 3 TORCH: INSTALLATION

3T.01 Torch Connections

If necessary, connect the torch to the Power Supply. Connect only the Thermal Dynamics model SL60 / Manual or SL100 / Mechanical Torch to this power supply. Maximum torch leads length is 100 feet / 30.5 m, including extensions.



WARNING

Disconnect primary power at the source before connecting the torch.

1. Align the ATC male connector (on the torch lead) with the female receptacle. Push the male connector into the female receptacle. The connectors should push together with a small amount of pressure.
2. Secure the connection by turning the locking nut clockwise until it clicks. **DO NOT** use the locking nut to pull the connection together. Do not use tools to secure the connection.

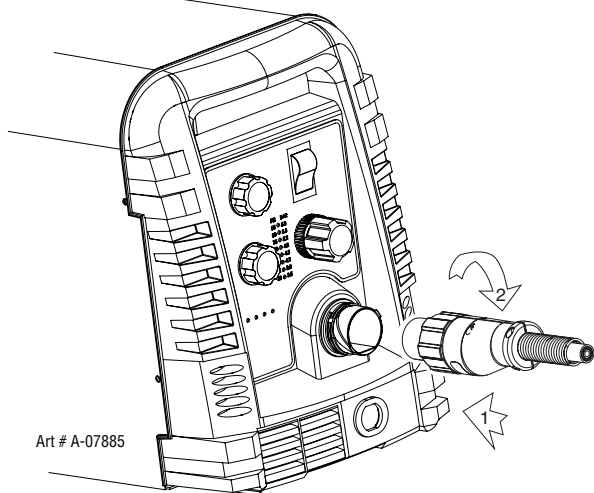

Connecting the Torch to the Power Supply

3. The system is ready for operation.

Check Air Quality

To test the quality of air:

1. Put the ON / OFF switch in the ON (up) position.
2. Put the Function Control switch in the SET position.
3. Place a welding filter lens in front of the torch and turn on the air. **Do not start an arc!**

Any oil or moisture in the air will be visible on the lens.

3T.02 Setting Up Mechanical Torch

NOTE

An adapter is required to be installed in the power supply if converting a hand torch system to operate a machine torch.



WARNING

Disconnect primary power at the source before disassembling the torch or torch leads.

The mechanical torch includes a positioning tube with rack and pinch block assembly.

1. Mount the torch assembly on the cutting table.
2. To obtain a clean vertical cut, use a square to align the torch perpendicular to the surface of the workpiece.

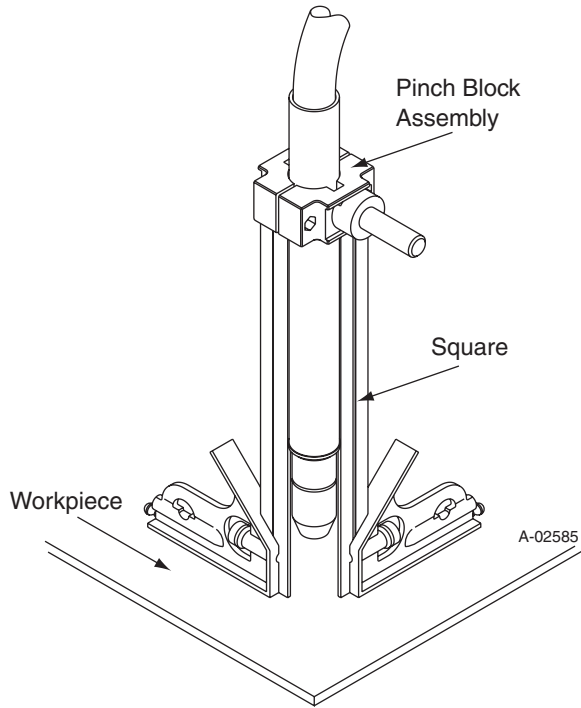

Mechanical Torch Set - Up

3. The proper torch parts (shield cup, tip, start cartridge, and electrode) must be installed for the type of operation. Refer to Section 4T.07, Torch Parts Selection for details.

SECTION 4 SYSTEM: OPERATION

4.01 Front Panel Controls / Features

See Illustration for numbering Identification

1. Output Current Control

Sets the desired output current. Output settings up to 60 Amps may be used for drag cutting (with the torch tip contacting the workpiece) or standoff cutting.



2. Function Control

Function Control Knob, Used to select between the different operating modes.

SET  Used to purge the air through the unit and torch and leads and to adjust gas pressure.

RUN  Used for general cutting operations

RAPID AUTO RESTART  Allows for faster restarting of the Pilot Arc for uninterrupted cutting.

LATCH   Used for longer hand held cuts. Once a cutting arc is established, the torch switch can be released. The cutting arc will remain on until the torch is lifted away from the work piece, the torch leaves the edge of the work piece the torch switch is activated again or if one of the system interlocks is activated.

3. On Off Power Switch

ON  / **OFF**  Switch controls input power to the power supply. Up is ON, down is OFF.

4. Air/Gas Pressure Control

The Pressure  Control is used in the "SET" mode to adjust the air/gas pressure. Pull the knob out to adjust and push in to lock.

5. AC Indicator

Steady light indicates power supply is ready for operation. Blinking light indicates unit is in protective interlock mode. Shut unit off, shut off or disconnect input power, correct the fault, and restart the unit. Refer to Section 5 for details.

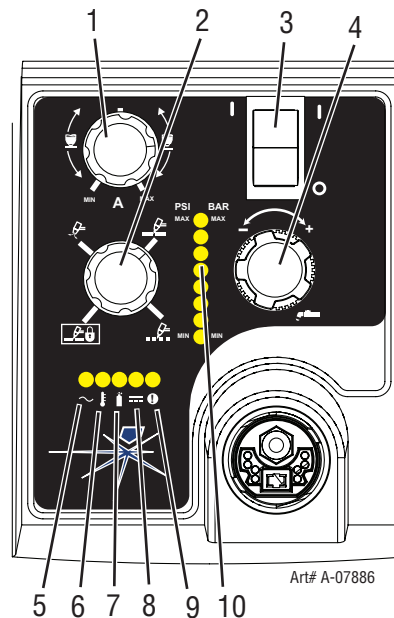

6. Temp Indicator

Indicator is normally OFF. Indicator is ON when internal temperature exceeds normal limits. Let the unit cool before continuing operation.

7. Gas Indicator

Indicator is ON when minimum input gas pressure for power supply operation is present. Minimum pressure for power supply operation is not sufficient for torch operation.

8. DC Indicator

Indicator is ON when DC output circuit is active.

9. Fault Error Indicator

Indicator is ON when Fault circuit is active. See section 5 for explanations of fault lights.

10. Pressure Indicators

PSI	BAR
MAX	MAX
90	6.3
85	5.9
80	5.5
75	5.2
70	4.8
65	4.5
MIN	MIN

Art # A-08170

The Indicators will illuminate according to the pressure set by the Pressure Control Knob (number 4).

4.02 Preparations for Operation

At the start of each operating session:



WARNING

Disconnect primary power at the source before assembling or disassembling power supply, torch parts, or torch and leads assemblies.

Torch Parts Selection

Check the torch for proper assembly and appropriate torch parts. The torch parts must correspond with the type of operation, and with the amperage output of this Power Supply (60 amps maximum). Refer to Section 4T.07 and following for torch parts selection.

Torch Connection

Check that the torch is properly connected. Only Thermal Dynamics model SL60 / Manual or SL100 / Mechanical Torches may be connected to this Power Supply. See Section 3T of this manual.

Check Primary Input Power Source

1. Check the power source for proper input voltage. Make sure the input power source meets the power requirements for the unit per Section 2, Specifications.
2. Connect the input power cable (or close the main disconnect switch) to supply power to the system.

Air Source

Ensure source meets requirements (refer to Section 2). Check connections and turn air supply on.

Connect Work Cable

Clamp the work cable to the workpiece or cutting table. The area must be free from oil, paint and rust. Connect only to the main part of the workpiece; do not connect to the part to be cut off.

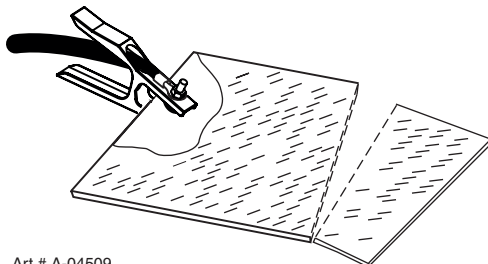

Art # A-04509

Power On

Place the Power Supply ON / OFF switch to the ON (up) position. AC indicator  turns on. Gas

indicator  turns on if there is sufficient gas pressure for power supply operation and the cooling fans turn on.

NOTE

Minimum pressure for power supply operation is lower than minimum for torch operation.

The cooling fans will turn on as soon as the unit is turned on. After the unit is idle for ten (10) minutes the fans will turn off. The fans will come back on as soon as the torch switch (Start Signal) is activated or if the unit is turned off, then turned on again. If an over temperature condition occurs, the fans will continue to run while the condition exists and for a ten (10) minute period once the condition is cleared.

Set Operating Pressure

1. Place the Power Supply Function Control knob to the SET  position. Gas will flow.
2. For Standoff cutting, adjust gas pressure from 70 - 85 psi / 4.8 - 5.9 bar (LED's in center of control panel). Refer to the Standoff chart for pressure setting details.

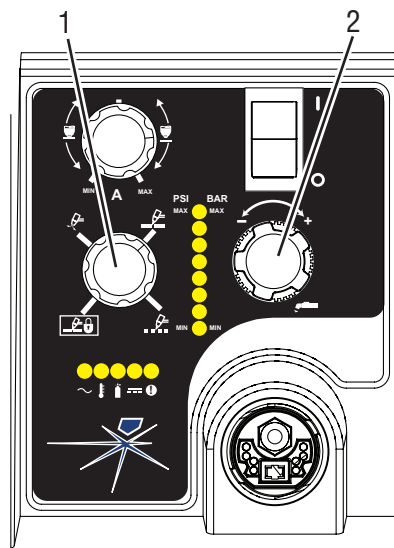

Art# A-07946

STANDOFF		
CutMaster 20mm Gas Pressure Settings		
Leads Length	SL60 (Hand Torch)	SL100 (Mechanized Torch)
Up to 25' (7.6 m)	75 psi 5.2 bar	75 psi 5.2 bar
Each additional 25' (7.6 m)	Add 5 psi 0.4 bar	Add 5 psi 0.4 bar

- For Drag cutting, adjust gas pressure from 75 - 95 psi / 5.2 - 6.5 bar (LED's in center of control panel). Refer to the Drag Cutting chart for pressure setting details.

DRAG	
CutMaster 20mm Gas Pressure Settings	
Leads Length	SL60 (Hand Torch)
Up to 25' (7.6 m)	80 psi 5.5 bar
Each additional 25' (7.6 m)	Add 5 psi 0.4 bar

Select Current Output Level

- Place the Function Control Knob in one of the three operating positions available:

RUN 

RAPID AUTO RESTART 

or LATCH   . Gas flow stops.

- Set the output current to desired amperage with the Output Current Control Knob.

Cutting Operation

When the torch leaves the workpiece during cutting operations with the Function Control Knob in the RUN position, there is a brief delay in restarting the pilot arc. With the knob in the **RAPID AUTO RESTART** position, when the torch leaves the workpiece the pilot arc restarts instantly, and the cutting arc restarts instantly when the pilot arc contacts the workpiece. (Use the 'Rapid Auto Restart' position when cutting expanded metal or gratings, or in gouging or trimming operations when an uninterrupted restart is desired). And with the knob in the LATCH position the main cutting arc will be maintained after the torch switch is released.

Typical Cutting Speeds



Cutting speeds vary according to torch output amperage, the type of material being cut, and operator skill. Refer to Section 4T.08 and following for greater details.

Output current setting or cutting speeds may be reduced to allow slower cutting when following a line, or using a template or cutting guide while still producing cuts of excellent quality.

Postflow

Release the trigger to stop the cutting arc. Gas continues to flow for approximately 20 seconds. During post - flow, if the user moves the trigger release to the rear and presses the trigger, the pilot arc starts. The main arc transfers to the workpiece if the torch tip is within transfer distance to the workpiece.

Shutdown

Turn the ON  / OFF  switch to OFF  (down). All Power Supply indicators shut off. Unplug the input power cord or disconnect input power. Power is removed from the system.

This Page Intentionally Blank

SECTION 4 TORCH: OPERATION

4T.01 Torch Parts Selection

Depending on the type of operation to be done determines the torch parts to be used.

Type of operation:

Drag cutting, standoff cutting or gouging

Torch parts:

Shield Cup, Cutting Tip, Electrode and Starter Cartridge

NOTE

Refer to Section 4T.07 and following for additional information on torch parts.

Change the torch parts for a different operation as follows:



WARNING

Disconnect primary power at the source before assembling or disassembling torch parts, or torch and leads assemblies.

NOTE

The shield cup holds the tip and starter cartridge in place. Position the torch with the shield cup facing upward to keep these parts from falling out when the cup is removed.

1. Unscrew and remove the shield cup assembly from the torch head.

2. Remove the Electrode by pulling it straight out of the Torch Head.

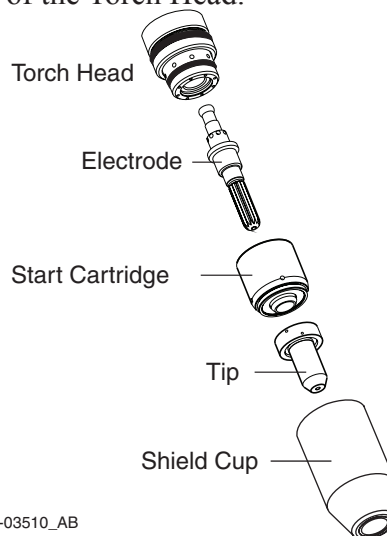

A-03510_AB

Torch Parts (Drag Shield Cap & Shield Cup Body Shown)

3. Install the replacement Electrode by pushing it straight into the torch head until it clicks.
4. Install the starter cartridge and desired tip for the operation into the torch head.
5. Hand tighten the shield cup assembly until it is seated on the torch head. If resistance is felt when installing the cup, check the threads before proceeding.

4T.02 Cut Quality

NOTES

Cut quality depends heavily on setup and parameters such as torch standoff, alignment with the workpiece, cutting speed, gas pressures, and operator ability.

Cut quality requirements differ depending on application. For instance, nitride build - up and bevel angle may be major factors when the surface will be welded after cutting. Dross - free cutting is important when finish cut quality is desired to avoid a secondary cleaning operation. The following cut quality characteristics are illustrated in the following figure:

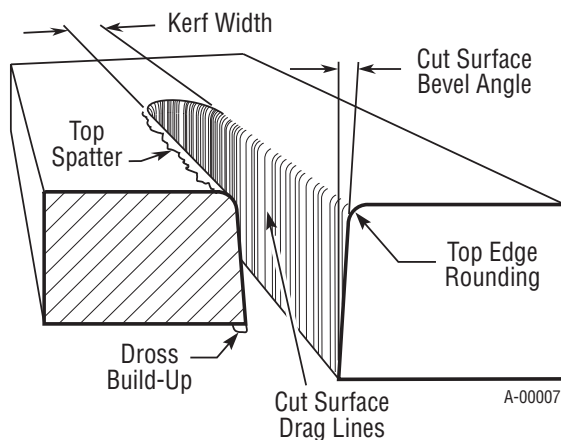

Cut Quality Characteristics

Cut Surface

The desired or specified condition (smooth or rough) of the face of the cut.

Nitride Build - Up

Nitride deposits can be left on the surface of the cut when nitrogen is present in the plasma gas stream. These buildups may create difficulties if the material is to be welded after the cutting process.

Bevel Angle

The angle between the surface of the cut edge and a plane perpendicular to the surface of the plate. A perfectly perpendicular cut would result in a 0° bevel angle.

Top - Edge Rounding

Rounding on the top edge of a cut due to wearing from the initial contact of the plasma arc on the workpiece.

Bottom Dross Buildup

Molten material which is not blown out of the cut area and resolidifies on the plate. Excessive dross may require secondary cleanup operations after cutting.

Kerf Width

The width of the cut (or the width of material removed during the cut).

Top Spatter (Dross)

Top spatter or dross on the top of the cut caused by slow travel speed, excess cutting height, or cutting tip whose orifice has become elongated.

4T.03 General Cutting Information



WARNINGS

Disconnect primary power at the source before disassembling the power supply, torch, or torch leads.

Frequently review the Important Safety Precautions at the front of this manual. Be sure the operator is equipped with proper gloves, clothing, eye and ear protection. Make sure no part of the operator's body comes into contact with the workpiece while the torch is activated.



CAUTION

Sparks from the cutting process can cause damage to coated, painted, and other surfaces such as glass, plastic and metal.

NOTE

Handle torch leads with care and protect them from damage.

Piloting

Piloting is harder on parts life than actual cutting because the pilot arc is directed from the electrode to the tip rather than to a workpiece. Whenever possible, avoid excessive pilot arc time to improve parts life.

Torch Standoff

Improper standoff (the distance between the torch tip and workpiece) can adversely affect tip life as well as shield cup life. Standoff may also significantly affect the bevel angle. Reducing standoff will generally result in a more square cut.

Edge Starting

For edge starts, hold the torch perpendicular to the workpiece with the front of the tip near (not touching) the edge of the workpiece at the point where the cut is to start. When starting at the edge of the plate, do not pause at the edge and force the arc to "reach" for the edge of the metal. Establish the cutting arc as quickly as possible.

Direction of Cut

In the torches, the plasma gas stream swirls as it leaves the torch to maintain a smooth column of gas. This swirl effect results in one side of a cut being more square than the other. Viewed along the direction of travel, the right side of the cut is more square than the left.

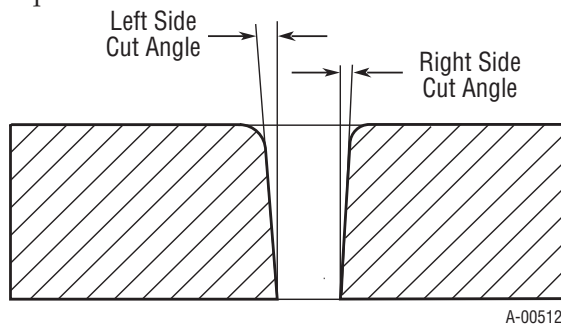

Side Characteristics Of Cut

To make a square - edged cut along an inside diameter of a circle, the torch should move counterclockwise around the circle. To keep the square edge along an outside diameter cut, the torch should travel in a clockwise direction.

Dross

When dross is present on carbon steel, it is commonly referred to as either "high speed, slow speed, or top dross". Dross present on top of the plate is normally caused by too great a torch to plate distance. "Top dross" is normally very easy to remove and can often be wiped off with a welding glove. "Slow speed dross" is normally present on the bottom edge of the plate. It can vary from a light to heavy bead, but does not adhere tightly to the cut edge, and can be easily scraped off. "High speed dross" usually forms a narrow bead along the bottom of the cut edge and is very difficult to remove. When cutting a troublesome steel, it is sometimes useful to reduce the cutting speed to produce "slow speed dross". Any resultant cleanup can be accomplished by scraping, not grinding.

4T.04 Hand Torch Operation

Standoff Cutting With Hand Torch

NOTE

For best performance and parts life, always use the correct parts for the type of operation.

1. The torch can be comfortably held in one hand or steadied with two hands. Position the hand to press the Trigger on the torch handle. With the hand torch, the hand may be positioned close to the torch head for maximum control or near the back end for maximum heat protection. Choose the holding technique that feels most comfortable and allows good control and movement.

NOTE

The tip should never come in contact with the workpiece except during drag cutting operations.

CUTMASTER 20mm

2. Depending on the cutting operation, do one of the following:
 - a. For **edge starts**, hold the torch perpendicular to the workpiece with the front of the tip on the edge of the workpiece at the point where the cut is to start.
 - b. For **standoff cutting**, hold the torch $1/8 - 3/8$ in (3-9 mm) from the workpiece as shown below.

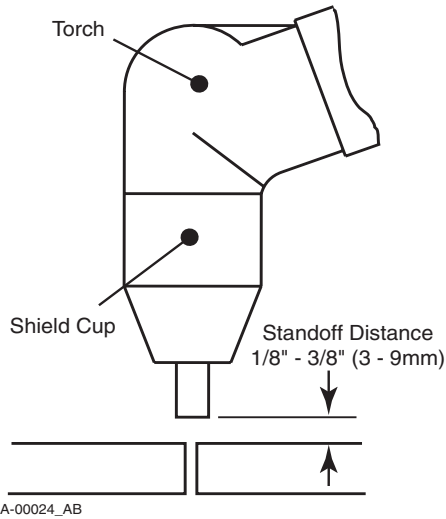

Standoff Distance

3. Hold the torch away from your body.
4. Slide the trigger release toward the back of the torch handle while simultaneously squeezing the trigger. The pilot arc will start.

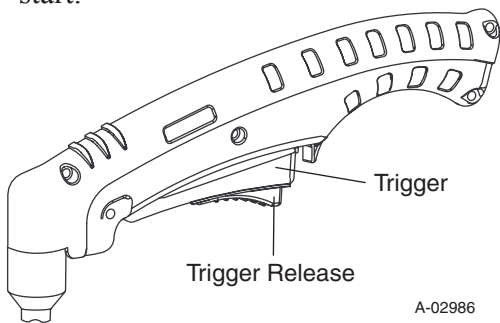

5. Bring the torch within transfer distance to the work. The main arc will transfer to the work, and the pilot arc will shut off.

NOTE

The gas preflow and postflow are a characteristic of the power supply and not a function of the torch.

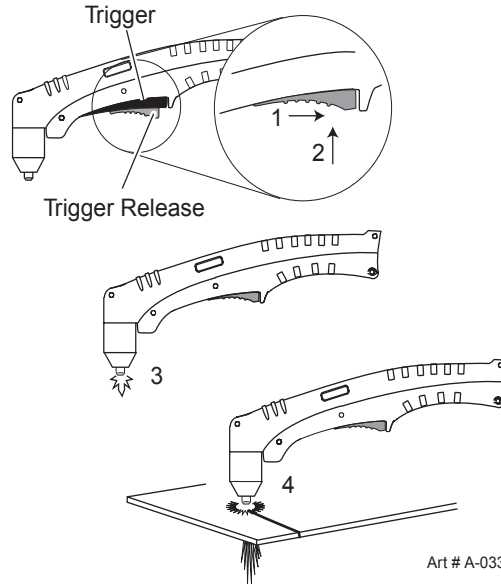

6. Cut as usual. Simply release the trigger assembly to stop cutting.
7. Follow normal recommended cutting practices as provided in the power supply operator's manual.

NOTE

When the shield cup is properly installed, there is a slight gap between the shield cup and the torch handle. Gas vents through this gap as part of normal operation. Do not attempt to force the shield cup to close this gap. Forcing the shield cup against the torch head or torch handle can damage components.

8. For a consistent standoff height from the workpiece, install the standoff guide by sliding it onto the torch shield cup. Install the guide with the legs at the sides of the shield cup body to maintain good visibility of the cutting arc. During operation, position the legs of the standoff guide against the workpiece.

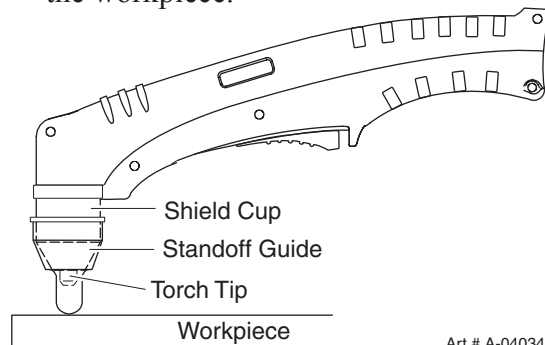

Shield Cup With Straight Edge

The drag shield cup can be used with a non conductive straight edge to make straight cuts by hand.



WARNING

The straight edge *must be non - conductive.*

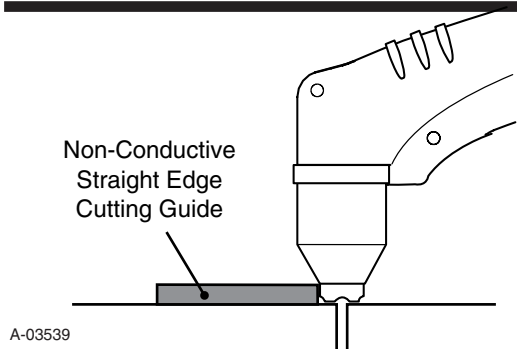

Using Drag Shield Cup With Straight Edge

The crown shield cup functions best when cutting 3/16 inch (4.7 mm) solid metal with relatively smooth surface.

Drag Cutting With a Hand Torch

Drag cutting works best on metal 1/4" (6 mm) thick or less.

NOTE

For best parts performance and life, always use the correct parts for the type of operation.

1. Install the drag cutting tip and set the output current.
2. The torch can be comfortably held in one hand or steadied with two hands. Position the hand to press the Trigger on the torch handle. With the hand torch, the hand may be positioned close to the torch head for maximum control or near the back end for maximum heat protection. Choose the holding technique that feels most comfortable and allows good control and movement.
4. Keep the torch in contact with the work-piece during the cutting cycle.
5. Hold the torch away from your body.

6. Slide the trigger release toward the back of the torch handle while simultaneously squeezing the trigger. The pilot arc will start.

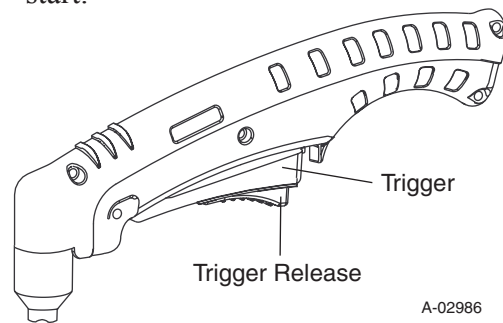

7. Bring the torch within transfer distance to the work. The main arc will transfer to the work, and the pilot arc will shut off.

NOTE

The gas preflow and postflow are a characteristic of the power supply and not a function of the torch.

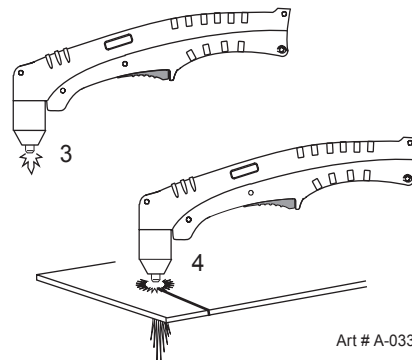
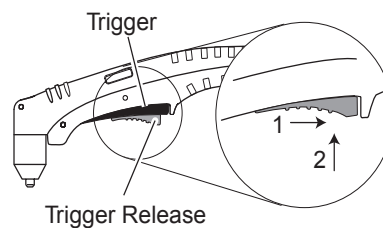

8. Cut as usual. Simply release the trigger assembly to stop cutting.
9. Follow normal recommended cutting practices as provided in the power supply operator's manual.

NOTE

When the shield cup is properly installed, there is a slight gap between the shield cup and the torch handle. Gas vents through this gap as part of normal operation. Do not attempt to force the shield cup to close this gap. Forcing the shield cup against the torch head or torch handle can damage components.

CUTMASTER 20mm

Piercing With Hand Torch

1. The torch can be comfortably held in one hand or steadied with two hands. Position the hand to press the Trigger on the torch handle. With the hand torch, the hand may be positioned close to the torch head for maximum control or near the back end for maximum heat protection. Choose the technique that feels most comfortable and allows good control and movement.

NOTE

The tip should never come in contact with the workpiece except during drag cutting operations.

2. Angle the torch slightly to direct blowback particles away from the torch tip (and operator) rather than directly back into it until the pierce is complete.
3. In a portion of the unwanted metal start the pierce off the cutting line and then continue the cut onto the line. Hold the torch perpendicular to the workpiece after the pierce is complete.
4. Hold the torch away from your body.
5. Slide the trigger release toward the back of the torch handle while simultaneously squeezing the trigger. The pilot arc will start.

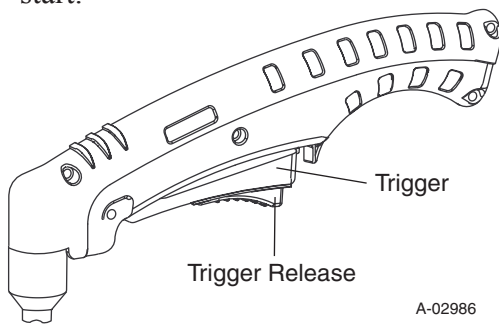

6. Bring the torch within transfer distance to the work. The main arc will transfer to the work, and the pilot arc will shut off.

NOTES

The gas preflow and postflow are a characteristic of the power supply and not a function of the torch.

When the shield cup is properly installed, there is a slight gap between the shield cup and the torch handle. Gas vents through this gap as part of normal operation. Do not attempt to force the shield cup to close this gap. Forcing the shield cup against the torch head or torch handle can damage components.

7. Clean spatter and scale from the shield cup and the tip as soon as possible. Spraying the shield cup in anti - spatter compound will minimize the amount of scale which adheres to it.

Cutting speed depends on material, thickness, and the operator's ability to accurately follow the desired cut line. The following factors may have an impact on system performance:

- Torch parts wear
- Air quality
- Line voltage fluctuations
- Torch standoff height
- Proper work cable connection

4T.05 Gouging



WARNINGS

Be sure the operator is equipped with proper gloves, clothing, eye and ear protection and that all safety precautions at the front of this manual have been followed. Make sure no part of the operator's body comes in contact with the workpiece when the torch is activated.

Disconnect primary power to the system before disassembling the torch, leads, or power supply.



CAUTION

Sparks from plasma gouging can cause damage to coated, painted or other surfaces such as glass, plastic, and metal.

Check torch parts. The torch parts must correspond with the type of operation. Refer to Section 4T.07, Torch Parts Selection.

Gouging Parameters

Gouging performance depends on parameters such as torch travel speed, current level, lead angle (the angle between the torch and workpiece), and the distance between the torch tip and workpiece (standoff).



CAUTION

Touching the torch tip or shield cup to the work surface will cause excessive parts wear.

Torch Travel Speed

NOTE

Refer to Appendix Pages for additional information as related to the Power Supply used.

Optimum torch travel speed is dependent on current setting, lead angle, and mode of operation (hand or machine torch).

Current Setting

Current settings depend on torch travel speed, mode of operation (hand or machine torch), and the amount of material to be removed.

Lead Angle

The angle between the torch and workpiece depends on the output current setting and torch travel speed. The recommended lead angle is 35°. At a lead angle greater than 45° the molten metal will not be blown out of the gouge and may be blown back onto the torch. If the lead angle is too small (less than 35°), less material may be removed, requiring more passes. In some applications, such as removing welds or working with light metal, this may be desirable.

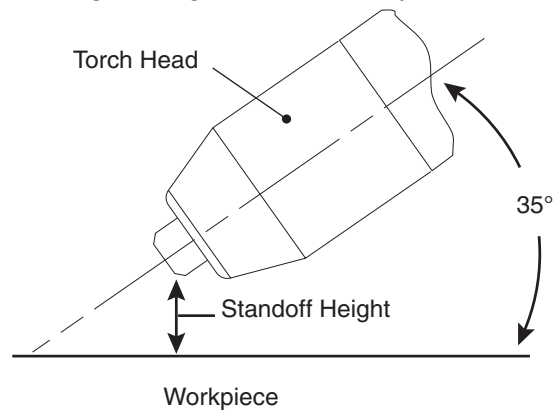

A-00941_AB

Gouging Angle and Standoff Distance

Standoff Distance

The tip to work distance affects gouge quality and depth. Standoff distance of 1/8 - 1/4 inch (3 - 6 mm) allows for smooth, consistent metal removal. Smaller standoff distances may result in a severance cut rather than a gouge. Standoff distances greater than 1/4 inch (6 mm) may result in minimal metal removal or loss of transferred main arc.

Slag Buildup

Slag generated by gouging on materials such as carbon and stainless steels, nickels, and alloyed steels, can be removed easily in most cases. Slag does not obstruct the gouging process if it accumulates to the side of the gouge path. However, slag build-up can cause inconsistencies and irregular metal removal if large amounts of material build up in front of the arc. The build-up is most often a result of improper travel speed, lead angle, or standoff height.

4T.06 Mechanized Torch Operation

Cutting With Mechanized Torch

The mechanized torch can be activated by remote control pendant or by a remote interface device such as CNC.

1. To start a cut at the plate edge, position the center of the torch along the edge of the plate.

Travel Speed

Proper travel speed is indicated by the trail of the arc which is seen below the plate. The arc can be one of the following:

1. Straight Arc

A straight arc is perpendicular to the workpiece surface. This arc is generally recommended for the best cut using air plasma on stainless or aluminum.

2. Leading Arc

The leading arc is directed in the same direction as torch travel. A five degree leading arc is generally recommended for air plasma on mild steel.

3. Trailing Arc

The trailing arc is directed in the opposite direction as torch travel.

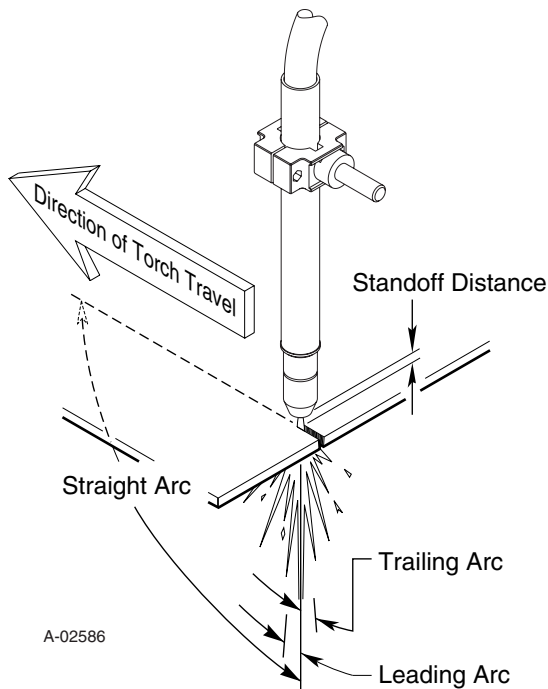

Mechanized Torch Operation

For optimum smooth surface quality, the travel speed should be adjusted so that only the leading edge of the arc column produces the cut. If the travel speed is too slow, a rough cut will be produced as the arc moves from side to side in search of metal for transfer.

Travel speed also affects the bevel angle of a cut. When cutting in a circle or around a corner, slowing down the travel speed will result in a squarer cut. The power source output should be reduced also. Refer to the appropriate Control Module Operating Manual for any Corner Slowdown adjustments that may be required.

Piercing With Machine Torch

To pierce with a machine torch, the arc should be started with the torch positioned as high as possible above the plate while allowing the arc to transfer and pierce. This standoff helps avoid having molten metal blow back onto the front end of the torch.

When operating with a cutting machine, a pierce or dwell time is required. Torch travel should not be enabled until the arc penetrates the bottom of the plate. As motion begins, torch standoff should be reduced to the recommended 1/8 - 1/4 inch (3-6 mm) distance for optimum speed and cut quality. Clean spatter and scale from the shield cup and the tip as soon as possible. Spraying or dipping the shield cup in anti-spatter compound will minimize the amount of scale which adheres to it.

4T.07 Parts Selection for SL60 Torch Cutting

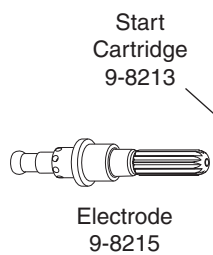
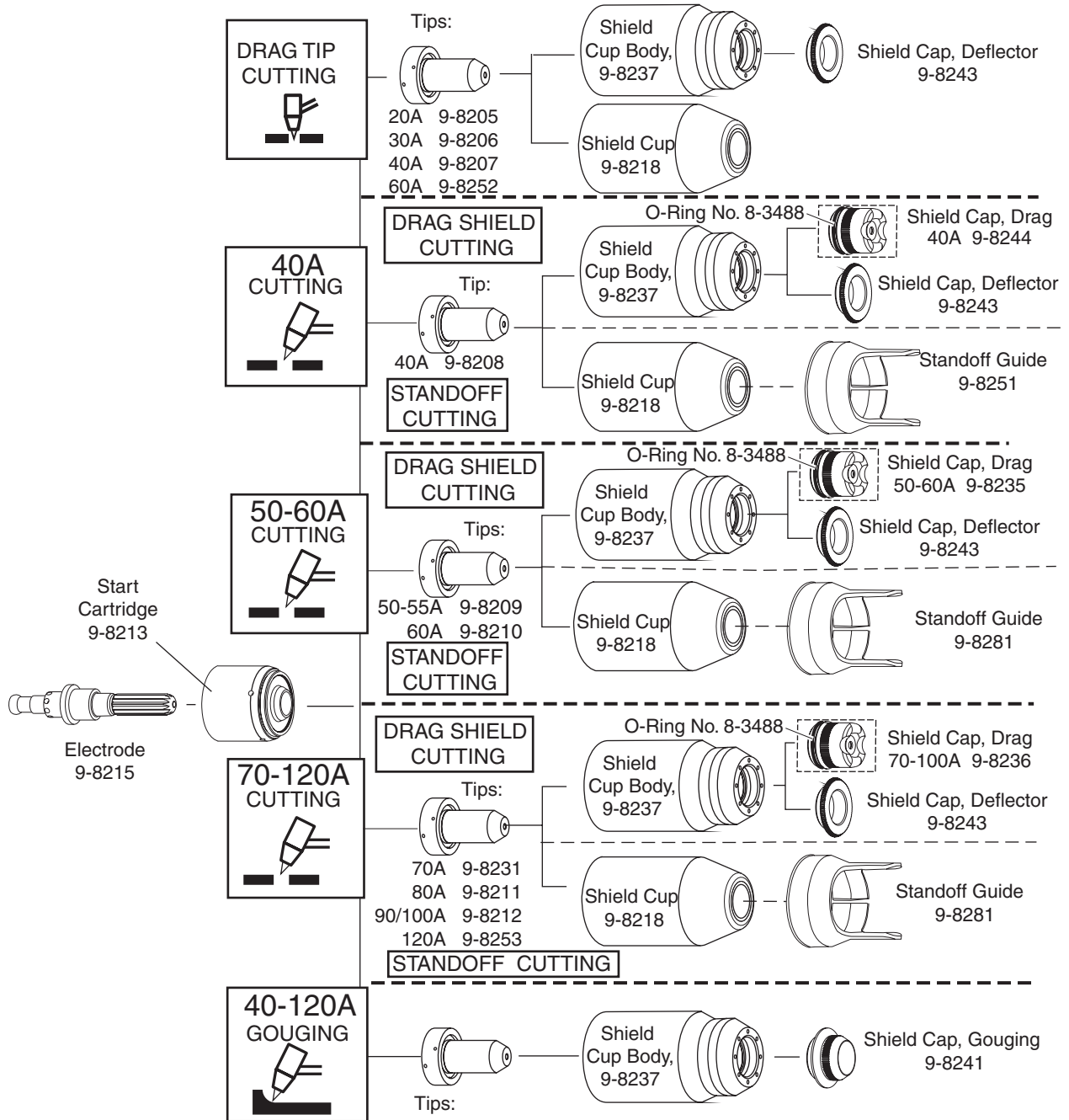

Art # A-08951

NOTE
 CutMaster 12mm uses 40A and less
 CutMaster 20mm uses 60A and less
 CutMaster 25mm uses 80A and less
 CutMaster 35mm uses 100A and less
 CutMaster 40mm uses 120A and less

CUTMASTER 20mm

4T.08 Recommended Cutting Speeds for SL60 Torch With Exposed Tip

Type Torch: SL60 With Exposed Tip							Type Material: Mild Steel								
Type Plasma Gas: Air							Type Secondary Gas: Single Gas Torch								
Thickness		Tip	Output	Amperage	Speed (Per Minute)		Standoff		Plasma Gas Press		Flow (CFH)		Pierce	Pierce Height	
Inches	mm	(Cat. No.)	Volts(VDC)	(Amps)	Inches	Meters	Inches	mm	psi*	bar	Plasma	Total**	Delay (Sec)	Inches	mm
0.036	0.9	9-8208	104	40	340	8.64	0.19	4.8	70	4.8	55	170	0.00	0.2	5.1
0.06	1.5	9-8208	108	40	250	6.35	0.19	4.8	70	4.8	55	170	0.10	0.2	5.1
0.075	1.9	9-8208	108	40	190	4.83	0.19	4.8	70	4.8	55	170	0.30	0.2	5.1
0.135	3.4	9-8208	110	40	105	2.67	0.19	4.8	70	4.8	55	170	0.40	0.2	5.1
0.188	4.8	9-8208	113	40	60	1.52	0.19	4.8	70	4.8	55	170	0.60	0.2	5.1
0.25	6.4	9-8208	111	40	40	1.02	0.19	4.8	70	4.8	55	170	1.00	0.2	5.1
0.375	9.5	9-8208	124	40	21	0.53	0.19	4.8	70	4.8	55	170	NR	NR	NR
0.500	12.7	9-8208	123	40	11	0.28	0.19	4.8	70	4.8	55	170	NR	NR	NR
0.625	15.9	9-8208	137	40	7	0.18	0.19	4.8	70	4.8	55	170	NR	NR	NR

Type Torch: SL60 With Exposed Tip							Type Material: Stainless Steel								
Type Plasma Gas: Air							Type Secondary Gas: Single Gas Torch								
Thickness		Tip	Output	Amperage	Speed (Per Minute)		Standoff		Plasma Gas Press		Flow (CFH)		Pierce	Pierce Height	
Inches	mm	(Cat. No.)	Volts(VDC)	(Amps)	Inches	Meters	Inches	mm	psi*	bar	Plasma	Total**	Delay (Sec)	Inches	mm
0.036	0.9	9-8208	103	40	355	9.02	0.125	3.2	70	4.8	55	170	0.00	0.2	5.1
0.05	1.3	9-8208	98	40	310	7.87	0.125	3.2	70	4.8	55	170	0.00	0.2	5.1
0.06	1.5	9-8208	98	40	240	6.10	0.125	3.2	70	4.8	55	170	0.10	0.2	5.1
0.078	2.0	9-8208	100	40	125	3.18	0.125	3.2	70	4.8	55	170	0.30	0.2	5.1
0.135	3.4	9-8208	120	40	30	0.76	0.187	4.8	70	4.8	55	170	0.40	0.2	5.1
0.188	4.8	9-8208	124	40	20	0.51	0.187	4.8	70	4.8	55	170	0.60	0.2	5.1
0.25	6.4	9-8208	122	40	15	0.38	0.187	4.8	70	4.8	55	170	1.00	0.2	5.1
0.375	9.5	9-8208	126	40	10	0.25	0.187	4.8	70	4.8	55	170	NR	NR	NR

Type Torch: SL60 With Exposed Tip							Type Material: Aluminum								
Type Plasma Gas: Air							Type Secondary Gas: Single Gas Torch								
Thickness		Tip	Output	Amperage	Speed (Per Minute)		Standoff		Plasma Gas Press		Flow (CFH)		Pierce	Pierce Height	
Inches	mm	(Cat. No.)	Volts(VDC)	(Amps)	Inches	Meters	Inches	mm	psi*	bar	Plasma	Total**	Delay (Sec)	Inches	mm
0.032	0.8	9-8208	110	40	440	11.18	0.187	4.8	70	4.8	55	170	0.00	0.2	5.1
0.051	1.3	9-8208	109	40	350	8.89	0.187	4.8	70	4.8	55	170	0.10	0.2	5.1
0.064	1.6	9-8208	112	40	250	6.35	0.187	4.8	70	4.8	55	170	0.10	0.2	5.1
0.079	2.0	9-8208	112	40	200	5.08	0.19	4.8	70	4.8	55	170	0.30	0.2	5.1
0.125	3.2	9-8208	118	40	100	2.54	0.19	4.8	70	4.8	55	170	0.40	0.2	5.1
0.188	4.8	9-8208	120	40	98	2.49	0.187	4.8	70	4.8	55	170	0.60	0.2	5.1
0.250	6.4	9-8208	123	40	50	1.27	0.187	4.8	70	4.8	55	170	1.00	0.2	5.1
0.375	9.5	9-8208	134	40	16	0.41	0.187	4.8	70	4.8	55	170	NR	NR	NR

Type Torch: SL60 With Exposed Tip							Type Material: Stainless Steel								
Type Plasma Gas: Air							Type Secondary Gas: Single Gas Torch								
Thickness		Tip	Output	Amperage	Speed (Per Minute)		Standoff		Plasma Gas Press		Flow (CFH)		Pierce	Pierce Height	
Inches	mm	(Cat. No.)	Volts(VDC)	(Amps)	Inches	Meters	Inches	mm	psi*	bar	Plasma	Total**	Delay (Sec)	Inches	mm
0.06	1.5	9-8210	119	60	350	8.91	0.19	4.8	75	5.2	90	245	0.00	0.20	5.1
0.075	1.9	9-8210	116	60	300	7.64	0.19	4.8	75	5.2	90	245	0.10	0.20	5.1
0.120	3.0	9-8210	123	60	150	3.82	0.19	4.8	75	5.2	90	245	0.10	0.20	5.1
0.135	3.4	9-8210	118	60	125	3.18	0.19	4.8	75	5.2	90	245	0.10	0.20	5.1
0.188	4.8	9-8210	122	60	90	2.29	0.19	4.8	75	5.2	90	245	0.20	0.20	5.1
0.250	6.4	9-8210	120	60	65	1.65	0.19	4.8	75	5.2	90	245	0.30	0.20	5.1
0.375	9.5	9-8210	130	60	30	0.76	0.19	4.8	75	5.2	90	245	0.50	0.20	5.1
0.500	12.7	9-8210	132	60	21	0.53	0.19	4.8	75	5.2	90	245	0.75	0.20	5.1
0.625	15.9	9-8210	130	60	15	0.38	0.19	4.8	75	5.2	90	245	NR	NR	NR
0.750	19.1	9-8210	142	60	12	0.31	0.25	6.4	75	5.2	90	245	NR	NR	NR

Type Torch: SL60 With Exposed Tip							Type Material: Mild Steel								
Type Plasma Gas: Air							Type Secondary Gas: Single Gas Torch								
Thickness		Tip	Output	Amperage	Speed (Per Minute)		Standoff		Plasma Gas Press		Flow (CFH)		Pierce	Pierce Height	
Inches	mm	(Cat. No.)	Volts(VDC)	(Amps)	Inches	Meters	Inches	mm	psi*	bar	Plasma	Total**	Delay (Sec)	Inches	mm
0.060	1.5	9-8210	110	60	290	7.37	0.19	4.8	75	5.2	90	245	0.00	0.19	4.8
0.075	1.9	9-8210	120	60	285	7.24	0.19	4.8	75	5.2	90	245	0.10	0.19	4.8
0.120	3.0	9-8210	120	60	180	4.57	0.19	4.8	75	5.2	90	245	0.10	0.19	4.8
0.135	3.4	9-8210	119	60	170	4.32	0.19	4.8	75	5.2	90	245	0.10	0.19	4.8
0.188	4.8	9-8210	121	60	100	2.54	0.19	4.8	75	5.2	90	245	0.20	0.19	4.8
0.250	6.4	9-8210	119	60	80	2.03	0.19	4.8	75	5.2	90	245	0.30	0.19	4.8
0.375	9.5	9-8210	124	60	50	1.27	0.19	4.8	75	5.2	90	245	0.50	0.19	4.8
0.500	12.7	9-8210	126	60	26	0.66	0.19	4.8	75	5.2	90	245	0.75	0.19	4.8
0.625	15.9	9-8210	127	60	19	0.48	0.19	4.8	75	5.2	90	245	NR	NR	NR
0.750	19.1	9-8210	134	60	14	0.36	0.19	4.8	75	5.2	90	245	NR	NR	NR
1.000	25.4	9-8210	140	60	6	0.15	0.19	4.8	75	5.2	90	245	NR	NR	NR

CUTMASTER 20mm

Type Torch: SL60 With Exposed Tip							Type Material: Aluminum								
Type Plasma Gas: Air							Type Secondary Gas: Single Gas Torch								
Thickness		Tip	Output	Amperage	Speed (Per Minute)		Standoff		Plasma Gas Press		Flow (CFH)		Pierce	Pierce Height	
Inches	mm	(Cat. No.)	Volts(VDC)	(Amps)	Inches	Meters	Inches	mm	psi*	bar	Plasma	Total**	Delay (Sec)	Inches	mm
0.060	1.5	9-8210	110	60	440	11.18	0.25	6.4	75	5.2	90	245	0.00	0.25	6.4
0.075	1.9	9-8210	110	60	440	11.18	0.25	6.4	75	5.2	90	245	0.10	0.25	6.4
0.120	3.0	9-8210	116	60	250	6.35	0.25	6.4	75	5.2	90	245	0.10	0.25	6.4
0.188	3.4	9-8210	116	60	170	4.32	0.25	6.4	75	5.2	90	245	0.20	0.25	6.4
0.250	6.4	9-8210	132	60	85	2.16	0.25	6.4	75	5.2	90	245	0.30	0.25	6.4
0.375	9.5	9-8210	140	60	45	1.14	0.25	6.4	75	5.2	90	245	0.50	0.25	6.4
0.500	12.7	9-8210	143	60	30	0.76	0.25	6.4	75	5.2	90	245	0.80	0.25	6.4
0.625	15.9	9-8210	145	60	20	0.51	0.25	6.4	75	5.2	90	245	NR	NR	NR
0.750	19.1	9-8210	145	60	18	0.46	0.25	6.4	75	5.2	90	245	NR	NR	NR

NOTES

* Gas pressure shown is for torches with leads up to 25' / 7.6 m long. For 50' / 15.2 m leads, refer to section 4.02 "Operating Pressure".

** Total flow rate includes plasma and secondary gas flow.

4T.09 Recommended Cutting Speeds for SL60 Torch With Shielded Tip

Type Torch: SL60 With Shielded Tip							Type Material: Mild Steel								
Type Plasma Gas: Air							Type Secondary Gas: Single Gas Torch								
Thickness		Tip	Output	Amperage	Speed (Per Minute)		Standoff		Plasma Gas Press		Flow (CFH)		Pierce	Pierce Height	
Inches	mm	(Cat. No.)	Volts (VDC)	(Amps)	Inches	Meters	Inches	mm	psi*	bar	Plasma	Total**	Delay (Sec)	Inches	mm
0.036	0.9	9-8208	114	40	170	4.32	0.19	4.8	70	4.8	55	170	0.00	0.2	5.1
0.06	1.5	9-8208	120	40	90	2.29	0.19	4.8	70	4.8	55	170	0.10	0.2	5.1
0.075	1.9	9-8208	121	40	80	2.03	0.19	4.8	70	4.8	55	170	0.30	0.2	5.1
0.135	3.4	9-8208	122	40	75	1.91	0.19	4.8	70	4.8	55	170	0.40	0.2	5.1
0.188	4.8	9-8208	123	40	30	0.76	0.19	4.8	70	4.8	55	170	0.60	0.2	5.1
0.25	6.4	9-8208	125	40	25	0.64	0.19	4.8	70	4.8	55	170	1.00	0.2	5.1
0.375	9.5	9-8208	138	40	11	0.28	0.19	4.8	70	4.8	55	170	NR	NR	NR
0.500	12.7	9-8208	142	40	7	0.18	0.19	4.8	70	4.8	55	170	NR	NR	NR
0.625	15.9	9-8208	152	40	3	0.08	0.19	4.8	70	4.8	55	170	NR	NR	NR

Type Torch: SL60 With Shielded Tip							Type Material: Stainless Steel								
Type Plasma Gas: Air							Type Secondary Gas: Single Gas Torch								
Thickness		Tip	Output	Amperage	Speed (Per Minute)		Standoff		Plasma Gas Press		Flow (CFH)		Pierce	Pierce Height	
Inches	mm	(Cat. No.)	Volts(VDC)	(Amps)	Inches	Meters	Inches	mm	psi*	bar	Plasma	Total**	Delay (Sec)	Inches	mm
0.036	0.9	9-8208	109	40	180	4.57	0.125	3.2	70	4.8	55	170	0.00	0.2	5.1
0.05	1.3	9-8208	105	40	165	4.19	0.125	3.2	70	4.8	55	170	0.00	0.2	5.1
0.06	1.5	9-8208	115	40	120	3.05	0.125	3.2	70	4.8	55	170	0.10	0.2	5.1
0.078	2.0	9-8208	120	40	65	1.65	0.187	4.8	70	4.8	55	170	0.30	0.2	5.1
0.135	3.4	9-8208	125	40	25	0.64	0.187	4.8	70	4.8	55	170	0.40	0.2	5.1
0.188	4.8	9-8208	132	40	20	0.51	0.187	4.8	70	4.8	55	170	0.60	0.2	5.1
0.25	6.4	9-8208	130	40	15	0.38	0.187	4.8	70	4.8	55	170	1.00	0.2	5.1
0.375	9.5	9-8208	130	40	10	0.25	0.187	4.8	70	4.8	55	170	NR	NR	NR

Type Torch: SL60 With Shielded Tip							Type Material: Aluminum								
Type Plasma Gas: Air							Type Secondary Gas: Single Gas Torch								
Thickness		Tip	Output	Amperage	Speed (Per Minute)		Standoff		Plasma Gas Press		Flow (CFH)		Pierce	Pierce Height	
Inches	mm	(Cat. No.)	Volts(VDC)	(Amps)	Inches	Meters	Inches	mm	psi*	bar	Plasma	Total**	Delay (Sec)	Inches	mm
0.032	0.8	9-8208	116	40	220	5.59	0.187	4.8	70	4.8	55	170	0.00	0.2	5.1
0.051	1.3	9-8208	116	40	210	5.33	0.187	4.8	70	4.8	55	170	0.00	0.2	5.1
0.064	1.6	9-8208	118	40	180	4.57	0.187	4.8	70	4.8	55	170	0.10	0.2	5.1
0.079	2.0	9-8208	116	40	150	3.81	0.19	4.8	70	4.8	55	170	0.30	0.2	5.1
0.125	3.2	9-8208	130	40	75	1.91	0.19	4.8	70	4.8	55	170	0.40	0.2	5.1
0.188	4.8	9-8208	132	40	60	1.52	0.187	4.8	70	4.8	55	170	0.60	0.2	5.1
0.250	6.4	9-8208	134	40	28	0.71	0.187	4.8	70	4.8	55	170	1.00	0.2	5.1
0.375	9.5	9-8208	143	40	11	0.28	0.187	4.8	70	4.8	55	170	NR	NR	NR

CUTMASTER 20mm

Type Torch: SL60 With Shielded Tip							Type Material: Mild Steel								
Type Plasma Gas: Air							Type Secondary Gas: Single Gas Torch								
Thickness		Tip	Output	Amperage	Speed (Per Minute)		Standoff		Plasma Gas Press		Flow (CFH)		Pierce	Pierce Height	
Inches	mm	(Cat. No.)	Volts (VDC)	(Amps)	Inches	Meters	Inches	mm	psi*	bar	Plasma	Total**	Delay (Sec)	Inches	mm
0.060	1.5	9-8210	124	60	250	6.35	0.19	4.8	75	5.2	90	245	0.00	0.2	5.1
0.075	1.9	9-8210	126	60	237	6.02	0.19	4.8	75	5.2	90	245	0.10	0.2	5.1
0.120	3.0	9-8210	126	60	230	5.84	0.19	4.8	75	5.2	90	245	0.10	0.2	5.1
0.135	3.4	9-8210	128	60	142	3.61	0.19	4.8	75	5.2	90	245	0.10	0.2	5.1
0.188	4.8	9-8210	128	60	125	3.18	0.19	4.8	75	5.2	90	245	0.20	0.2	5.1
0.250	6.4	9-8210	123	60	80	2.03	0.19	4.8	75	5.2	90	245	0.30	0.2	5.1
0.375	9.5	9-8210	132	60	34	0.86	0.19	4.8	75	5.2	90	245	0.50	0.2	5.1
0.500	12.7	9-8210	137	60	23	0.58	0.19	4.8	75	5.2	90	245	0.75	0.2	5.1
0.625	15.9	9-8210	139	60	14	0.36	0.19	4.8	75	5.2	90	245	NR	NR	NR
0.750	19.1	9-8210	145	60	14	0.36	0.19	4.8	75	5.2	90	245	NR	NR	NR
1.000	25.4	9-8210	156	60	4	0.10	0.19	4.8	75	5.2	90	245	NR	NR	NR

Type Torch: SL60 With Shielded Tip							Type Material: Stainless Steel								
Type Plasma Gas: Air							Type Secondary Gas: Single Gas Torch								
Thickness		Tip	Output	Amperage	Speed (Per Minute)		Standoff		Plasma Gas Press		Flow (CFH)		Pierce	Pierce Height	
Inches	mm	(Cat. No.)	Volts(VDC)	(Amps)	Inches	Meters	Inches	mm	psi*	bar	Plasma	Total**	Delay (Sec)	Inches	mm
0.06	1.5	9-8210	110	60	165	4.19	0.13	3.2	75	5.2	90	245	0.00	0.20	5.1
0.075	1.9	9-8210	116	60	155	3.94	0.13	3.2	75	5.2	90	245	0.10	0.20	5.1
0.120	3.0	9-8210	115	60	125	3.18	0.13	3.2	75	5.2	90	245	0.10	0.20	5.1
0.135	3.4	9-8210	118	60	80	2.03	0.13	3.2	75	5.2	90	245	0.10	0.20	5.1
0.188	4.8	9-8210	120	60	75	1.91	0.13	3.2	75	5.2	90	245	0.20	0.20	5.1
0.250	6.4	9-8210	121	60	60	1.52	0.13	3.2	75	5.2	90	245	0.30	0.20	5.1
0.375	9.5	9-8210	129	60	28	0.71	0.13	3.2	75	5.2	90	245	0.50	0.20	5.1
0.500	12.7	9-8210	135	60	17	0.43	0.19	4.8	75	5.2	90	245	0.75	0.20	5.1
0.625	15.9	9-8210	135	60	14	0.36	0.19	4.8	75	5.2	90	245	NR	NR	NR
0.750	19.1	9-8210	142	60	10	0.25	0.19	4.8	75	5.2	90	245	NR	NR	NR

Type Torch: SL60 With Shielded Tip							Type Material: Aluminum								
Type Plasma Gas: Air							Type Secondary Gas: Single Gas Torch								
Thickness		Tip	Output	Amperage	Speed (Per Minute)		Standoff		Plasma Gas Press		Flow (CFH)		Pierce	Pierce Height	
Inches	mm	(Cat. No.)	Volts(VDC)	(Amps)	Inches	Meters	Inches	mm	psi*	bar	Plasma	Total**	Delay (Sec)	Inches	mm
0.060	1.5	9-8210	105	60	350	8.89	0.13	3.2	75	5.2	90	245	0.00	0.20	5.1
0.075	1.9	9-8210	110	60	350	8.89	0.13	3.2	75	5.2	90	245	0.10	0.20	5.1
0.120	3.0	9-8210	110	60	275	6.99	0.13	3.2	75	5.2	90	245	0.10	0.20	5.1
0.188	3.4	9-8210	122	60	140	3.56	0.13	3.2	75	5.2	90	245	0.20	0.20	5.1
0.250	6.4	9-8210	134	60	80	2.03	0.19	4.8	75	5.2	90	245	0.30	0.20	5.1
0.375	9.5	9-8210	140	60	45	1.14	0.19	4.8	75	5.2	90	245	0.50	0.20	5.1
0.500	12.7	9-8210	144	60	26	0.66	0.19	4.8	75	5.2	90	245	0.80	0.20	5.1
0.625	15.9	9-8210	145	60	19	0.48	0.19	4.8	75	5.2	90	245	NR	NR	NR
0.750	19.1	9-8210	150	60	15	0.38	0.19	4.8	75	5.2	90	245	NR	NR	NR

NOTES

* *Gas pressure shown is for torches with leads up to 25' / 7.6 m long. For 50' / 15.2 m leads, refer to section 4.02 "Operating Pressure".*

** *Total flow rate includes plasma and secondary gas flow.*

PATENT INFORMATION

Plasma Cutting Torch Patents

The following parts are covered under U.S. and Foreign Patents as follows:

Catalog #	Description	Patent(s)
9-8215	Electrode	US Pat No(s) 6163008; 6987238 Other Pat(s) Pending
9-8213	Cartridge	US Pat No(s) 6903301; 6717096; 6936786; 6703581; D496842; D511280; D492709; D499620; D504142 Other Pat(s) Pending
9-8205	Tip	US Pat No(s) 6774336; 7145099; 6933461 Other Pat(s) Pending
9-8206	Tip	US Pat No(s) 6774336; 7145099; 6933461 Other Pat(s) Pending
9-8207	Tip	US Pat No(s) 6774336; 7145099; 6933461 Other Pat(s) Pending
9-8252	Tip	US Pat No(s) 6774336; 7145099; 6933461 Other Pat(s) Pending
9-8208	Tip	US Pat No(s) 6774336; 7145099; 6933461 Other Pat(s) Pending
9-8209	Tip	US Pat No(s) 6774336; 7145099; 6933461 Other Pat(s) Pending
9-8210	Tip	US Pat No(s) 6774336; 7145099; 6933461 Other Pat(s) Pending
9-8231	Tip	US Pat No(s) 6774336; 7145099; 6933461 Other Pat(s) Pending
9-8211	Tip	US Pat No(s) 6774336; 7145099; 6933461 Other Pat(s) Pending
9-8212	Tip	US Pat No(s) 6774336; 7145099; 6933461 Other Pat(s) Pending
9-8253	Tip	US Pat No(s) 6774336; 7145099; 6933461 Other Pat(s) Pending
9-8225	Tip	US Pat No(s) 6774336; 7145099; 6933461 Other Pat(s) Pending
9-8226	Tip	US Pat No(s) 6774336; 7145099; 6933461 Other Pat(s) Pending
9-8227	Tip	US Pat No(s) 6774336; 7145099; 6933461 Other Pat(s) Pending
9-8228	Tip	US Pat No(s) 6774336; 7145099; 6933461 Other Pat(s) Pending
9-8241	Shield Cap	US Pat No(s) 6914211; D505309 Other Pat(s) Pending
9-8243	Shield Cap	US Pat No(s) 6914211; D493183 Other Pat(s) Pending
9-8235	Shield Cap	US Pat No(s) 6914211; D505309 Other Pat(s) Pending
9-8236	Shield Cap	US Pat No(s) 6914211; D505309 Other Pat(s) Pending
9-8237	Shield Cup	US Pat No(s) 6914211; D501632; D511633 Other Pat(s) Pending
9-8238	Shield Cap	US Pat No(s) 6914211; D496951 Other Pat(s) Pending
9-8239	Shield Cap	US Pat No(s) 6914211; D496951 Other Pat(s) Pending
9-8244	Shield Cap	US Pat No(s) 6914211; D505309 Other Pat(s) Pending

Catalog #	Description	Patent(s)
9-8245	Shield Cap	US Pat No(s) 6914211; D496951 Other Pat(s) Pending

The following parts are also licensed under U.S. Patent No. 5,120,930 and 5,132,512:

Catalog #	Description
9-8235	Shield Cap
9-8236	Shield Cap
9-8237	Shield Cup
9-8238	Shield Cap
9-8239	Shield Cap
9-8244	Shield Cap
9-8245	Shield Cap

This Page Intentionally Blank

SECTION 5 SYSTEM: SERVICE

5.01 General Maintenance



Warning!
Disconnect input power before maintaining.

Maintain more often
if used under severe
conditions

Each Use

Visual check of
torch tip and electrode



Weekly

Visually inspect the torch body tip,
electrode, start cartridge and shield cup



Visually inspect the
cables and leads.
Replace as needed



3 Months

Replace all
broken parts



Clean
exterior
of power supply

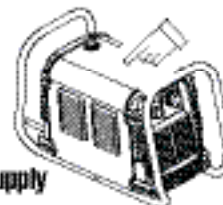

6 Months

Visually check and
Carefully clean the
interior

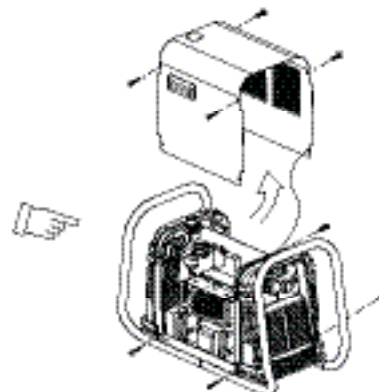

CUTMASTER 20mm

5.02 Maintenance Schedule

NOTE

The actual frequency of maintenance may need to be adjusted according to the operating environment.

Daily Operational Checks or Every Six Cutting Hours:

1. Check torch consumable parts, replace if damaged, worn or when cut performance has diminished.
2. Check plasma and secondary supply and pressure.
3. Purge plasma gas line to remove any moisture build-up.

Weekly or Every 30 Cutting Hours:

1. Check fan for proper operation and adequate air flow.
2. Inspect torch for any cracks or exposed wires, replace if necessary.
3. Inspect input power cable for damage or exposed wires, replace if necessary.

Six Months or Every 720 Cutting Hours:

1. Check the in-line air filter(s), clean or replace as required
2. Check cables and hoses for leaks or cracks, replace if necessary.
3. Check all contactor points for severe arcing or pits, replace if necessary.
4. Vacuum dust and dirt *out* of the entire machine.



CAUTION

Do not blow air into the power supply during cleaning. Blowing air into the unit can cause metal particles to interfere with sensitive electrical components and cause damage to the unit.

5.03 Common Faults

Problem - Symptom	Common Cause
Insufficient Penetration	1. Cutting speed too fast. 2. Torch tilted too much. 3. Metal too thick. 4. Worn torch parts 5. Cutting current too low. 6. Non - Genuine Thermal Dynamics parts used 7. Incorrect gas pressure
Main Arc Extinguishes	1. Cutting speed too slow. 2. Torch standoff too high from workpiece. 3. Cutting current too high. 4. Work cable disconnected. 5. Worn torch parts. 6. Non - Genuine Thermal Dynamics parts used
Excessive Dross Formation	1. Cutting speed too slow. 2. Torch standoff too high from workpiece. 3. Worn torch parts. 4. Improper cutting current. 5. Non - Genuine Thermal Dynamics parts used 6. Incorrect gas pressure
Short Torch Parts Life	1. Oil or moisture in air source. 2. Exceeding system capability (material too thick). 3. Excessive pilot arc time 4. Gas pressure too low. 5. Improperly assembled torch. 6. Non - Genuine Thermal Dynamics parts used
Difficult Starting	1. Worn torch parts. 2. Non - Genuine Thermal Dynamics parts used. 3. Incorrect gas pressure.

5.04 Fault Indicator

At initial power up, two lights will temporarily illuminate for 2-3 seconds to show the version of software used.

To determine the first digit, count the function indicators left to right, 1 through 5. To determine the second digit count the pressure indicators, reading from bottom to top, 0 through 7. In the example below the Temp indicator and 75 psi indicators are on indicating the version would be 2.3.

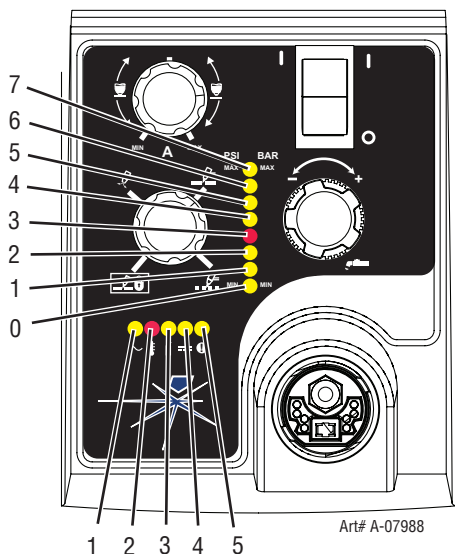

When the "Fault" indicator is on or blinking it will be accompanied by one of the pressure indicator lights depending on what the Fault is. Only one of these faults will be displayed at one time. If more than one fault exists, when the first fault is corrected and cleared, the next fault will then be displayed. It is possible to have a fault indicated in the function indicators and another fault indicated in the pressure indicators. The following table shows each of the Faults possible.

Pressure Indicator	Fault
Max	Over Pressure
90	Internal Error
85	Shorted Torch
80	Consumables Missing
75	Start Error
70	Parts in Place
65	Input Power
Min	Under Pressure

NOTE

Fault explanations are covered in the following tables.

Explanation of Faults

" UNDER PRESSURE: Indicates that operating pressure is set too low and power supply output power will be disabled.

PART IN PLACE: Indicates that the shield cup is not properly installed or tightened.

START ERROR: Indicates that the START SIGNAL was active (ie. Torch Trigger depressed, hand held pendant switch on or CNC signal for torch on) during one of three conditions:

- 1) During initial power up when ON/OFF switch is turned to ON position
- 2) When fault which had been disabling the system is cleared.
- 3) When the FUNCTION CONTROL SWITCH Mode is moved from SET position to any of the other three (3) modes of operation.

CONSUMABLES MISSING: Indicates that the electrode, start cartridge or tip is missing or excessively worn.

SHORTED TORCH: Indicates the torch or lead has a shorted condition between positive and negative leads.

INTERNAL ERROR: Indicates a microprocessor error.

OVER PRESSURE: Indicates that operating pressure is set too high. The Error Indicator will not flash when the pressure is above 95 PSI. This LED will remain on and the system will operate but pilot starting and cut performance may be affected.

NOTE

The cooling fans will turn on as soon as the unit is turned on. After the unit is idle for ten (10) minutes the fans will turn off. The fans will come back on as soon as the torch switch (Start Signal) is activated or if the unit is turned off, then turned on again. If an over temperature condition occurs, the fans will continue to run while the condition exists and for a ten (10) minute period once the condition is cleared.

5.05 Basic Troubleshooting Guide

WARNING

There are extremely dangerous voltage and power levels present inside this unit. Do not attempt to diagnose or repair unless you have had training in power electronics measurement and troubleshooting techniques.

Problem - Symptom	Possible Cause	Recommended Action
ON / OFF Switch is on but the A/C Indicator does not light	<ol style="list-style-type: none"> 1. Primary power disconnect is in OFF position. 2. Primary fuses / breakers are blown or tripped. 3. Faulty components in unit. 	<ol style="list-style-type: none"> 1. Turn primary power disconnect switch to ON position. 2. a) Have qualified person check primary fuses / breakers. b) Connect unit to known good primary power receptacle 3. Return to authorized service center for repair or replacement.
FAULT indicator flashing, 65 PSI indicator flashing	<ol style="list-style-type: none"> 1. Incorrect Primary line Voltage. 2. Primary input voltage problem. 3. Faulty components in unit. 	<ol style="list-style-type: none"> 1. Check that appropriate line voltage is connected to unit. 2. Have qualified person check primary voltage to insure it meets unit requirements see section 2.04. 3. Return to authorized service center for repair or replacement.
TEMPERATURE indicator on. FAULT indicator flashing.	<ol style="list-style-type: none"> 1. Air flow through or around the unit is obstructed. 2. Duty cycle of the unit has been exceeded 3. Failed components in unit 	<ol style="list-style-type: none"> 1. Refer to clearance information – section 2.04 2. Allow unit to cool. 3. Return to authorized service center for repair or replacement.
GAS indicator off, FAULT and MIN pressure indicators flashing.	<ol style="list-style-type: none"> 1. Gas supply not connected to unit. 2. Gas supply not turned on. 3. Gas supply pressure too low. 4. AIR PRESSURE CONTROL regulator set too low. 5. Failed components in unit. 	<ol style="list-style-type: none"> 1. Connect gas supply to unit. 2. Turn gas supply on. 3. Set air supply inlet pressure to unit to 120 psi. 4. Adjust regulator to set air pressure - see section 4.02. 5. Return to authorized service center for repair or replacement.
FAULT and 70 PSI indicators flashing.	<ol style="list-style-type: none"> 1. Shield Cup loose. 2. Torch not properly connected to power supply. 3. Problem in torch and leads PIP circuit. 4. Failed components in unit. 	<ol style="list-style-type: none"> 1. Hand tighten the shield cup until it is snug. 2. Insure torch ATC is securely fastened to unit. 3. Replace torch and leads or return to authorized service center for repair or replacement. 4. Return to authorized service center for repair or replacement.
FAULT and 75 PSI indicators flashing.	<ol style="list-style-type: none"> 1. Start signal is active when ON/OFF SWITCH is turned to ON position. 2. Problem in the torch and leads switch circuit. 3. Failed components in unit. 	<ol style="list-style-type: none"> 1. Start can be active for one of the following: <ul style="list-style-type: none"> • Hand torch switch held closed • Hand pendant switch held closed • CNC START signal is active low Release the START signal source 2. Replace torch and leads or return to authorized service center for repair or replacement. 3. Return to authorized service center for repair or replacement.

Problem - Symptom	Possible Cause	Recommended Action
FAULT & 80 PSI indicators flashing. Gas flow is cycling on and off.	<ol style="list-style-type: none"> 1. Torch shield cup is loose. 2. Torch tip, electrode or starter cartridge missing. 3. Torch start cartridge is stuck. 4. Open conductor in torch leads. 5. Problem in the torch and leads switch circuit. 6. Failed components in unit. 	<ol style="list-style-type: none"> 1. Tighten shield cup by hand. Do not overtighten. 2. Turn off power supply. Remove shield cup. Install missing parts. 3. Turn off power supply. Bleed down system pressure. Remove shield cup, tip and start cartridge. Check start cartridge lower end fitting for free movement. Replace if fitting does not move freely. 4. Replace torch and leads or return to authorized service center for repair or replacement. 5. Replace torch and leads or return to authorized service center for repair or replacement. 6. Return to authorized service center for repair or replacement.
Nothing happens when torch switch or remote switch is closed (Or CNC START signal is active) No gas flow, DC LED OFF.	<ol style="list-style-type: none"> 1. Problem in the torch and leads switch circuit (Remote pendant switch circuit). 2. CNC Contoller device not providing Start signal. 3. Failed components in unit. 	<ol style="list-style-type: none"> 1. Take Torch and Leads (Remote Pendant) to Authorized Repair Facility. 2. Contact Controller manufacturer. 3. Return to authorized service center for repair or replacement.
FAULT indicator flashing and 85 PSI indicators flashing. at 1 cycle per second.	<ol style="list-style-type: none"> 1. Upper O-Ring on torch head is in wrong position. 2. Torch start cartridge is stuck. 3. Worn or faulty torch parts. 4. Shorted Torch. 	<ol style="list-style-type: none"> 1. Remove shield cup from torch; check upper O-Ring position; correct if necessary. 2. Turn off power supply. Bleed down system pressure. Remove shield cup, tip and start cartridge. Check start cartridge lower end fitting for free movement. Replace if fitting does not move freely. 3. Inspect torch consumable parts. Replace if necessary. 4. Replace torch and leads or return to an authorized service center for repair.
FAULT indicator flashing and 85 PSI indicators flashing. at 5 cycles per second	<ol style="list-style-type: none"> 1. Low output voltage during pilot. 2. Low output voltage during cut. 3. For Automation Torch only: Tip contacted work piece during cut with output current set above 45 amps. 	<ol style="list-style-type: none"> 1. Low output voltage during pilot. 2. Low output voltage during cut. 3. For Automation Torch only: Tip contacted work piece during cut with output current set above 45 amps.
No Fault lights on, no arc in torch.	<ol style="list-style-type: none"> 1. Failed components in unit. 	<ol style="list-style-type: none"> 1. Return to an authorized service center for repair.
FAULT and 90 PSI indicators flashing	<ol style="list-style-type: none"> 1. Internal Error 	<ol style="list-style-type: none"> 1. Turn the ON / OFF switch OFF then back ON again. If that does not clear the fault, return to an authorized service center for repair.
Pilot arc is on but cutting arc will not establish	<ol style="list-style-type: none"> 1. Work cable not connected to work piece. 2. Work cable/connector broken. 3. Failed components in unit. 	<ol style="list-style-type: none"> 1. Connect work cable. 2. Replace work cable. 3. Return to an authorized service center for repair.
Torch cutting is diminished	<ol style="list-style-type: none"> 1. Incorrect current setting. 2. Worn torch consumables. 3. Poor work cable connection to work piece. 4. Torch being moved too fast. 5. Excessive oil or water in torch. 6. Failed components in unit. 	<ol style="list-style-type: none"> 1. Check and adjust to proper setting. 2. Check torch consumables and replace as needed. 3. Check the connection of the Work Lead to the work piece. 4. Reduce cutting speed. 5. Refer to "Check air quality" in section 3 Torch. 6. Return to an authorized service center for repair.

5.06 Power Supply Basic Parts Replacement



WARNING

Disconnect primary power to the system before disassembling the torch, leads, or power supply.

This section describes procedures for basic parts replacement. For more detailed parts replacement procedures, refer to the Power Supply Service Manual.

A. Cover Removal

1. Remove the upper and lower screws which secure the cover to the main assembly. Do not loosen the lower screws inside the cut out slots in the bottom of the cover.

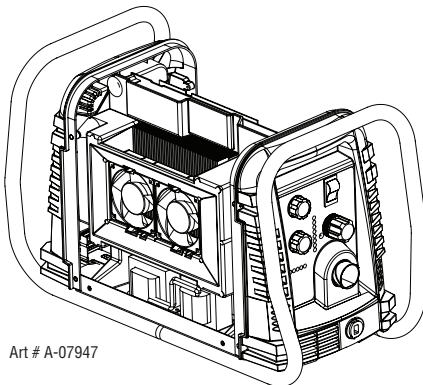
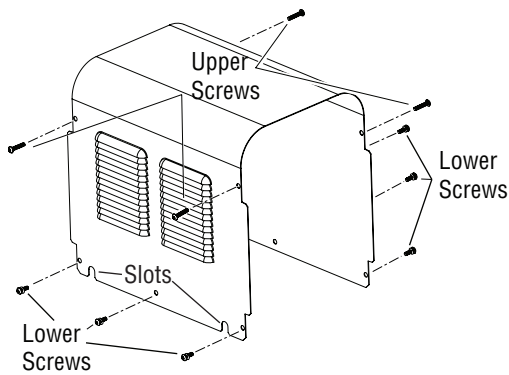

2. Carefully pull the Cover up and away from the unit.

B. Cover Installation

1. Reconnect the ground wire, if necessary.
2. Place the cover onto the power supply so that slots in the bottom edges of the cover engage the lower screws.
3. Tighten lower screws.
4. Reinstall and tighten the upper screws.

C. Filter Element Assembly Replacement

The Filter Element Assembly is in the rear panel. For better system performance, the filter element should be checked per the Maintenance Schedule (Subsection 5.02), and either cleaned or replaced.

1. Remove power from the power supply; turn off the gas supply and bleed down the system.
2. Remove the system cover. See "A Cover Removal" in this section.
3. Locate the internal air line and the fitting from the filter assembly. Number 1 in the following illustration.
4. Hold a wrench or similar tool against the locking ring on the filter assembly fitting, then pull on the hose to release it. (Numbers 2 and 3 in the following illustration).

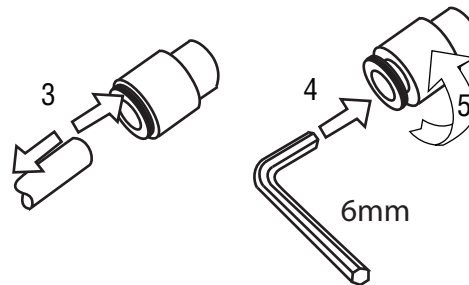
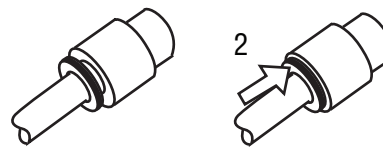
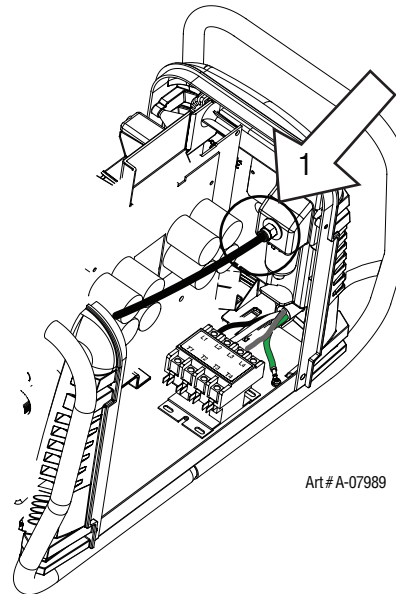

5. Remove the fitting from the filter element assembly by inserting a 6 mm hex wrench into the internal hex fitting and turning it counter clock-wise (left). Numbers 4 and 5 in the previous illustration.

6. Disconnect the input line from the filter element assembly.
7. Remove the filter element assembly through the rear opening.

NOTE

If replacing or cleaning just the filter element refer to the following illustration for disassembly.

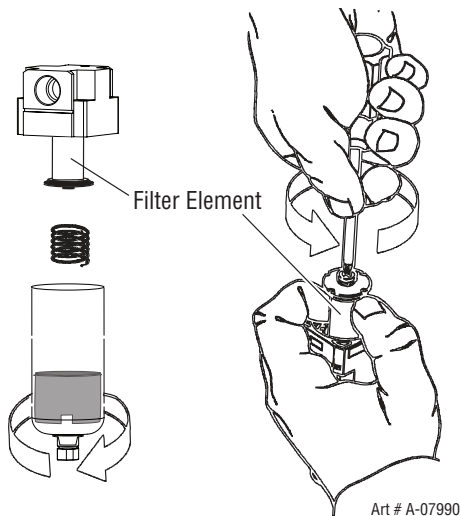

8. Install the new or cleaned assembly by reversing these procedures.
9. Turn on the air supply and check for leaks before reinstalling the cover.

Optional Single-Stage Filter Element Replacement

These instructions apply to power supplies where the optional Single-Stage Filter has been installed.

The Power Supply shuts down automatically when the Filter Element becomes completely saturated. The Filter Element can be removed from its housing, dried, and reused. Allow 24 hours for Element to dry. Refer to Section 6, Parts List, for replacement filter element catalog number.

1. Remove power from power supply.
2. Shut off air supply and bleed down system before disassembling Filter to change Filter Element.
3. Disconnect gas supply hose.
4. Turn the Filter Housing Cover counter-clockwise and remove it. The Filter Element is located inside the Housing.

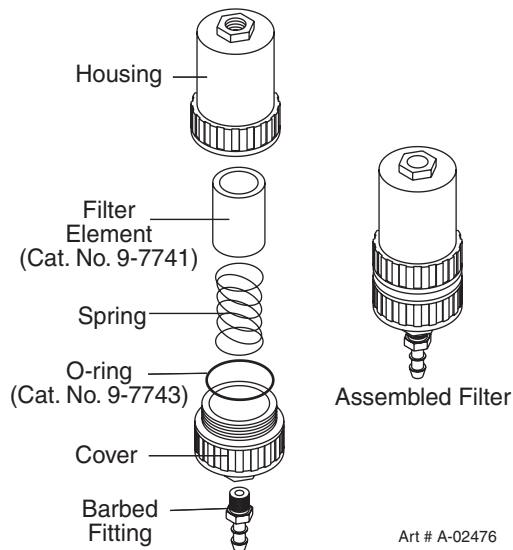

Optional Single-Stage Filter Element Replacement

5. Remove the Filter Element from the Housing and set Element aside to dry.
6. Wipe inside of housing clean, then insert the replacement Filter Element open side first.
7. Replace Housing on Cover.
8. Reattach gas supply.

NOTE

If unit leaks between housing and cover, inspect the "O" Ring for cuts or other damage.

CUTMASTER 20mm

Optional Two-Stage Filter Element Replacement

The Two-Stage Air Filter has two Filter Elements. When the Filter Elements become dirty the Power Supply will continue to operate but cut quality may become unacceptable. Refer to Section 6, Parts List, for replacement filter element catalog number.

1. Shut off primary input power.
2. Shut off air supply and bleed down system.



WARNING

Always turn off the air supply and bleed the system before disassembling the Filter Assembly as injury could result.

3. Loosen the two bolts on the top of the Filter Assembly enough to allow the Filter Elements to move freely.
4. Note the location and orientation of the old Filter Elements.
5. Slide out the old Filter Elements.

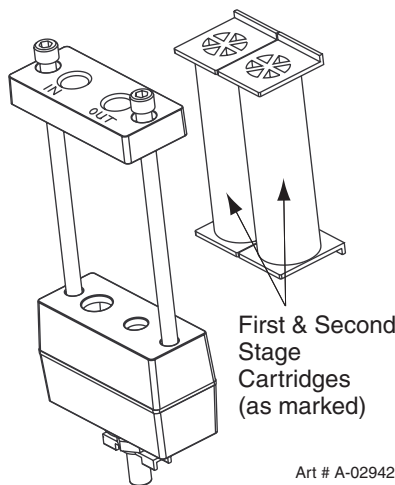

Optional Two-Stage Filter Replacement

6. Slide the replacement Filter Elements into the Filter Assembly, with the same orientation as noted in Step 4 above.
7. Hand tighten the two bolts evenly, then torque each bolt to 20 - 30 in-lbs (2.3 - 3.4 Nm). Improper torque may damage the gasket.
8. Slowly apply air pressure to the assembly, checking for leaks.

NOTE

A small amount of air leakage from the bottom fitting is normal.

This completes the parts replacement procedures.

5.07 Circuit Fault Isolation



WARNING

The following procedures should not be attempted by anyone who has not had proper training or authorized to do so.

A. Cover Removal

1. Remove the upper and lower screws which secure the cover to the main assembly. Do not loosen the lower screws inside the cut out slots in the bottom of the cover.

Note

The upper screws and lower screws are not the same. Do not mix them. The upper screws are for threading into the plastic of the front and rear panels. DO NOT use the finer threaded lower screws for this.

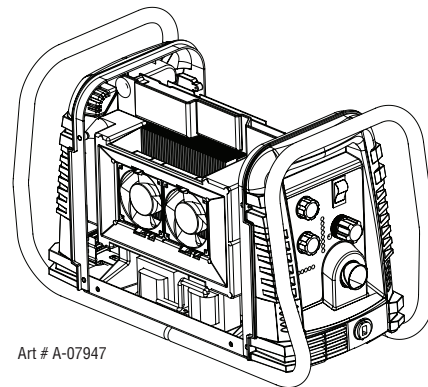
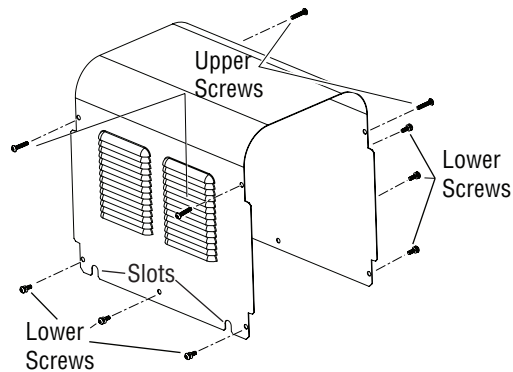

2. Carefully pull the Cover up and away from the unit.

B. Cover Installation

1. Reverse previous procedures for cover installation.

NOTE

When installing the upper screws, attempt to reuse the original threads. The easiest way to do this is by turning the screw counter-clockwise until you feel the threads lign up, then begin to turn the screw clockwise to tighten to 15-18 in. lbs.. Do not over tighten.

C. Pre Power Up Tests

Prior to applying primary line power to the unit, perform the following checks to prevent component failure or blowing primary fuses. The troubleshooting guide will assume these tests were done and no failure was found or that any failures found were corrected.

1. Main Contactor (W1) Check – Section 5.12 A
2. Input Diode Module Test – Section 5.12 B
3. Input Capacitor Pcb Test –Section 5.12 C
4. IGBT Modules Test – Section 5.12 D
5. Output Diode Module Test – Section 5.12 E
6. Pilot IGBT Test – Section 5.12 F

If all of the Pre Power-Up Tests are ok, proceed with the trouble shooting guide.



CAUTION

Due to the close proximity of the Main Pcb to the Capacitor Pcb, It is recommended to use an insulated meter probe when making measurements on the J2 connector on the Main Pcb. Do not short between the pins. Do not short to the Capacitor Pcb connections.

D. Initial Set up Conditions

This section is to help isolate the defective circuit before troubleshooting, identify symptoms, and test the unit for proper operation. Follow the instructions as given to identify the possible symptom(s) and the defective circuit. After repairs are complete, run the following tests again to verify that the unit is fully operational.

1. Connect gas supply to rear of Power Supply.
2. Turn on gas supply and set operating pressure per pressure setting label on power supply.

3. Set the Power Supply controls as follows:
 - ON/OFF SWITCH to OFF position
 - Turn FUNCTION CONTROL SWITCH to SET position
 - CURRENT CONTROL POTENTIOMETER to MAXIMUM position, fully clockwise.

E. Main Input and Internal Power Test

1. Connect Primary Line power to the unit.
2. Turn the ON/OFF SWITCH (SW1) to ON position and observe the following:
 - Software version is displayed (See section 5.04 Fault Indicators)

After approx. three (3) seconds

 - Inrush relay on PCB1 energizes, starting pre-charging of working capacitors.
 - W1 energizes
 - AC and GAS Indicators come on
 - Gas flows
 - Fans turn on
3. Adjust the pressure regulator to set the gas pressure as specified in charts.

STANDOFF		
CutMaster 20mm Gas Pressure Settings		
Leads Length	SL60 (Hand Torch)	SL100 (Mechanized Torch)
Up to 25' (7.6 m)	75 psi 5.2 bar	70 psi 4.8 bar
Each additional 25' (7.6 m)	Add 5 psi 0.4 bar	Add 5 psi 0.4 bar

DRAG		
CutMaster 20mm Gas Pressure Settings		
Leads Length	SL60 (Hand Torch)	SL100 (Mechanized Torch)
Up to 25' (7.6 m)	80 psi 5.5 bar	75 psi 5.2 bar
Each additional 25' (7.6 m)	Add 5 psi 0.4 bar	Add 5 psi 0.4 bar

4. Turn FUNCTION CONTROL SWITCH to RUN position
 - Solenoid turns off, gas stops flowing (pressure display may increase slightly when gas is not flowing)

This completes the Main Input and Internal Power Test. If the above are all correct then proceed to the next section "F. Pilot Arc Test". If the unit does not function as stated above, then note the symptom and proceed to Section "5.07, Main Input and Internal Power Problems".

F. Pilot Arc Test

1. Activate or depress the torch switch (Activate START signal) to establish a pilot arc and note the following
 - Gas solenoid opens
 - Gas flows
 - After two seconds the gas solenoid closes and gas stops flowing momentarily, then gas solenoid re-opens and gas resumes flowing
 - DC LED comes on
 - Pilot arc is established
2. Open the torch switch (Remote Pendant switch or remove CNC start signal)
 - Gas continues to flow
 - DC LED goes off

After 20 second post flow time

- Gas solenoid closes
- Gas flow stops

This completes the Pilot Arc Test. If the above are all correct then proceed to the next section "G, Main Arc and Controls Test". If the unit does not function as stated above, then note the symptom and proceed to Section "5.08, Pilot Arc Problems".

G. Main Arc and Controls Test

Connect work Cable to the work piece, Close torch switch (Pendant switch or activate CNC Start) to establish a pilot arc. Bring torch to within 1/8" – 3/8" of the work piece to establish main cutting arc.

- Main Cutting Arc Establishes
 - On Main Pcb D59 turns off and D78 turns on
1. Clamp DC ammeter around the work cable. Output will be 60 amps.
 2. While cutting, adjust the CURRENT CONTROL POTENTIOMETER from maximum setting to minimum setting.
 - Current adjusts from 60amps down to 20 amps
 3. Set the CURRENT CONTROL POTENTIOMETER to maximum position.
 - Current adjusts from 20 amps up to 60 amps
 4. While cutting keep the torch switch closed, bring the torch off the edge of the material.
 - Cutting arc extinguishes
 - Gas solenoid closes
 - Gas flow stops momentarily then restarts when solenoid opens
 - Pilot arc ignites
 5. Open the torch switch
 - DC LED turns off

After 20 second post flow time

- Gas solenoid closes
 - Gas flow stops
6. Set the FUNCTION CONTROL SWITCH to RAPID AUTO RESTART mode.
 7. Close torch switch (Pendant switch or activate CNC Start) to establish a pilot arc. Bring torch to within 1/8" – 3/8" of the work piece to establish main cutting arc.
 8. While cutting keep the torch switch closed and bring the torch off the edge of the material.
 - Pilot Arc re-ignites immediately

9. Open the torch switch
 - DC LED turns off
- After 20 second post flow time
- Gas solenoid closes
 - Gas flow stops
10. Set the FUNCTION CONTROL SWITCH to LATCH mode
 11. Start a cut, and release the torch switch
 - Main cutting arc will remain on until the torch is lifted away from the plate approx 3/4" or until the torch is brought off the edge of the metal

Once the arc has extinguished

- DC LED turns off

After 20 second post flow time

- Gas solenoid closes
- Gas flow stops

This completes the Main Arc and Controls Test. If the above are all correct then proceed to the next section "H CNC Interface Test." If the unit does not function as stated above, then note the symptom and proceed to Section "5.09, Main Arc and Controls Problems".

H. CNC INTERFACE TEST

If the unit has one of the two factory supplied options for CNC interface installed, proceed with this section, otherwise the tests are complete.

1. Connect an ohmmeter between J2-12 to J2-14 (START signal). Position the torch to pilot. Check the OK-TO-MOVE signal by connecting a jumper between J2-3 and J2-4 (START signal).
 - Pilot arc is established
2. Bring the torch to the work piece and transfer to cutting arc.
 - OK-TO-MOVE signal is present. (Meter shows continuity)

3. Remove jumper from J2.
 - Arc shuts off
 - OK-TO-MOVE signal off (Meter shows no continuity)
 - Gas continues to flow
 - DC LED goes off

After 20 second Post flow time

- Gas solenoid closes
- Gas flow stops

If the unit has the Basic CNC Interface harness the test is complete. If the unit does not function as stated above, then note the symptom and proceed to Section "5.10 CNC Interface Problems". If the unit has the Automation Interface PCB installed, continue with this section.

4. There are three (3) ARC VOLTS signals available from the J2 connector.
 - a) J2-9 (+) to J2-7 (-)
 - b) J2-5 (+) to J2-6 (-) (Auto Interface pcb J3 connector with jumper installed between pins 1 and 2) = ARC VOLTS divided by 50
 - c) J2-5 (+) to J2-6 (-) (Auto Interface pcb J3 connector with jumper installed between pins 2 and 3) = ARC VOLTS divided by 16

Measure the voltage between these points while piloting (Open Circuit Voltage) and while cutting. The voltages should approx as listed below

Open Circuit Voltage	Cutting Voltage
a) 300 VDC	100 VDC
b) 6 VDC	2 VDC
c) 19 DVC	6 VDC

This completes the CNC Interface Test. If the above are all correct then the unit is functioning correctly. If the unit does not function as stated, then note the symptom and proceed to Section "5.10, CNC Interface Problems".

5.08 Main Input and Internal Power Problems

A. Primary input line fuse blows as soon as primary disconnect is closed.

1. Primary input cable installed incorrectly.
 - a) For Non EMC units - Check wiring of primary power cable to the W1 contactor

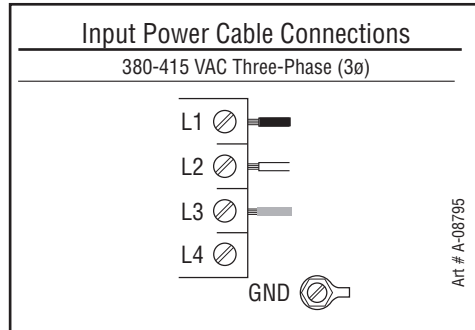

- b) For EMC units - Check wiring of primary power cable to the EMC Filter terminal block.

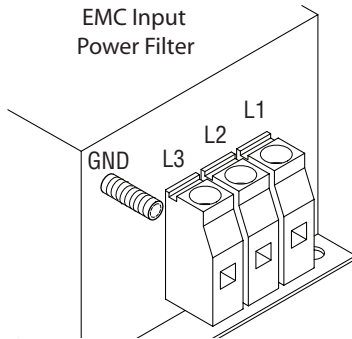

Three Phase Input Power Wiring

2. W1 contactor points are stuck closed
 - a) Check per section 5.11A
 3. Primary plug not wired correctly.
 - a) Check manufacturer's plug installation instructions.
 4. Primary input cable is defective.
 - a) Check cable for shorts.
- ### B. Primary line fuses blow immediately after ON/OFF SWITCH (SW1) is turned to ON position.
1. Shorted Input Diode Module
 - a) Check per section 5.11B
 2. Shorted Input Capacitor Pcb
 - a) Check per section 5.11C

C. Gas flows with ON/OFF SWITCH in OFF position

1. Foreign debris has lodged in gas solenoid.
 - a) Replace gas solenoid. This is a problem caused by improperly filtered air supply. Customer needs to add filtration to air supply prior to unit inlet.

D. All front panel indicators are off, fans do not run. Main Contactor W1 does not close.

1. Primary power not connected.
 - a) Check that cable is connected to primary power.
2. Primary line fuse/breaker is blown/tripped.
 - a) Replace fuse or reset breaker.
3. Defective ON/OFF SWITCH
 - a) Check continuity
4. Defective Main Pcb
 - a) Measure Main Pcb power supply voltages at the following test points
GND1 to +12V = 12VDC
GND1 to +48V = 48 VDC

Replace Main Pcb if not correct

5. Defective Ribbon Cable
 - a) Check continuity
 6. Defective Logic
 - a) Replace Logic Pcb
- ### E. AC LED on, W1 contactor does not energize. (In earlier revision units, the fan MOT1 will come on after approx 20 seconds)

1. Defective contactor.
 - a) Measure for 24vac between wires 5 & 6. If voltage is present, replace W1.
2. Defective Logic PCB 3.
 - a) Measure /W1_ON signal on Logic PCB 3 between J1-9 to TP1. Voltage should be 12VDC then drop to less than 1vdc, 2 seconds after turning SW1 to ON.

3. Open or improperly connected ribbon cable to J2 connector on Main PCB 1
 - a) Inspect connection and check continuity. Replace if open.
- 4) Defective Main PCB 1.
 - a) Replace Main PCB 1.

F. UNDER PRESSURE FAULT. AC LED on, FAULT Indicator and 60 PSI LED flashing.

1. Air pressure source to unit is too low.
 - a) Set input pressure source to 90-100PSI.
2. Regulator set too low.
 - a) Adjust unit regulator to increase pressure.
3. Defective Logic PCB 3
 - a) Measure for 5VDC on the Logic PCB 3 between J3-3 to J3-1. Replace Logic PCB 3 if voltage is not present or low.
 - b) Measure for voltage on the Logic PCB 3 between J3-2 to J3-1. If the voltage is between 3-4.5VDC, replace the Logic PCB 3.
4. Defective Pressure Transducer
 - a) Replace Pressure Transducer

G. INPUT POWER FAULT. AC LED on, FAULT Indicator and 65 PSI LED flashing.

1. Primary line voltage out of tolerance range.
 - a) Connect unit to voltage with unit specifications. See section "2.04 Power supply specifications". If using a generator, connect unit to a wall receptacle to see if problem is corrected.
- 2 Defective Main PCB 1
 - a) Measure voltage on Main PCB 1 between test point GND1 to J2-22.
400 VAC input = approx 2.6 VDC

If voltage is less than 2vdc, replace Main PCB 1.

3. Defective Ribbon cable.
 - a) Check continuity of the ribbon cable connecting between the Main PCB 1 and the Logic PCB 3.
4. Defective Logic PCB 3.
 - a) Replace Logic PCB 3.

H. PARTS-IN-PLACE (PIP) FAULT. The FAULT Indicator and 70 PSI LED is flashing.

1. Shield Cup loose
 - a) Hand tighten the shield cup to close the PIP switch
2. Torch not properly connected to power supply
 - a) Insure torch ATC is securely fastened to unit.
3. Problem with torch and leads PIP circuit
 - a) Check continuity of torch PIP circuit at ATC pins 1 & 2.
Negative / Plasma Lead

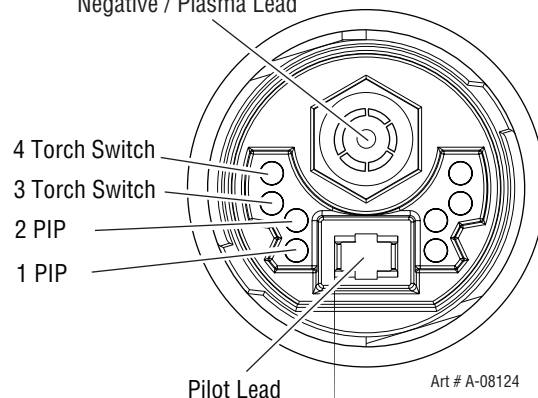

4. Defective Logic Pcb
 - a) Measure the voltage on Main Pcb between J2-17 to test point GND1 for 12VDC. If the voltage is less than 2VDC, Replace Logic Pcb
5. Defective Main Pcb
 - a) Replace Main Pcb

CUTMASTER 20mm

I. START ERROR FAULT. The FAULT Indicator and 75 PSI LED is flashing.

1. Start signal is active when SW1 is turned to ON position.
 - a) Start can be active for one of the following:
 - Hand torch switch held closed
 - Hand pendant switch held closed
 - CNC START signal is active low

Release the START signal source

2. Problem in the torch and leads switch circuit
 - a) Check continuity of torch switch circuit at ATC pins 3 & 4. See previous illustration.
3. Short in CNC cable
 - a) Check continuity
4. Defective Logic Pcb (PCB3)
 - a) Measure voltage at Main PCB between J2-16 to test point GND1 for 12VDC. If voltage is present, replace Logic PCB
5. Defective Main PCB
 - a) Replace Main PCB.

J. TIP MISSING FAULT. The FAULT Indicator and 80 PSI LED is flashing. Gas solenoid cycles on and off.

1. Torch Shield Cup is loose.
 - a) Tighten shield cup by hand. Do not over tighten.
2. Torch tip, electrode, or starter cartridge missing.
 - a) Turn off power supply. Replace missing part(s).
3. Starter Cartridge is stuck.
 - a) Turn off power supply. Bleed down the system. Remove the shield cup, tip, start cartridge and electrode. Check the lower end unit of the start cartridge for free movement. Replace the cartridge if the lower end unit does not move freely.

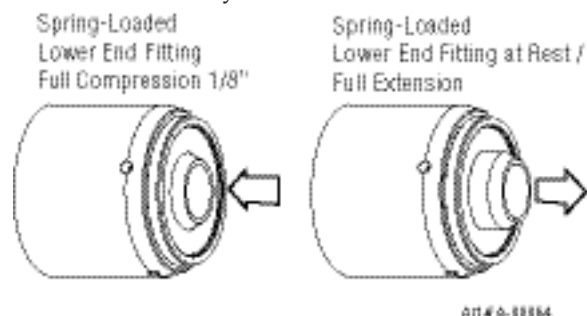

4. Open conductor in torch leads
 - a) Check continuity
5. Defective Main PCB
 - b) Measure voltage at Main Pcb between J2-2 to test point GND1 for 12VDC. If voltage is present, replace Main PCB
6. Defective Logic PCB
 - a) Replace Logic PCB

K. AC LED on, yellow TEMP LED is on, red FAULT Indicator is flashing.

1. Air flow through unit is restricted
 - a) Provide adequate airflow. See Ventillation Clearance Requirements section 2.04.
2. Exceeded duty cycle of the power supply.
 - a) Allow unit to remain on, but at idle, with fan running to cool power supply. See Power Supply Specifications section 2.04 for duty cycle information.

NOTE

When the unit is turned on the cooling fans MOT1 & 2 will remain off. (In earlier units MOT1 will turn on for .one (1) second and then turns off) The fans will turn on when a START signal (Torch Switch, Remote Pendant switch, or CNC START) is active and will remain on for ten (10) minutes after the START signal is removed. If an over temperature condition occurs, the fans will continue to run while the condition exists and for a ten (10) minute period after the condition is cleared.

3. Fan(s) not turning
 - a) Measure voltage at plug between J7-1 to J7-2 and between J81 to J8-2 on Main Pcb for 12VDC If voltage is present replace fan.
4. Defective Main PCB
 - a) Measure voltage at plug between J7-1 to J7-2 and between J8-1 to J8-2 on Main Pcb for 12VDC. If voltage is missing at either receptacle, replace Main PCB.
5. Defective Logic PCB
 - a) Replace Logic PCB

L. AC LED on, TEMP, GAS, DC LED's are off, FAULT Indicator is flashing. MIN PRESSURE LED is flashing. Gas is not flowing

1. Gas supply not connected to unit
 - a) Connect gas supply to unit
2. Gas supply not turned on
 - a) Turn gas supply on
3. Gas supply pressure too low.
 - a) Set gas supply pressure to 95-120psi
4. Air Pressure Control Regulator set too low.
 - a) Adjust AIR PRESSURE CONTROL to set pressure as specified in section 4.02 Setting Operational Pressure.

M. INTERNAL ERROR

FAULT Indicator and 90 PSI Indicator flashing

1. There has been a microprocessor problem.
 - a) Turn ON/OFF SWITCH to OFF position and then turn to ON position to clear the error

N. MAX PRESSURE ERROR

MAX Pressure LED is lit.

1. Gas pressure set too high
 - a) Reduce gas pressure
2. Defective Logic PCB
 - a) Replace Logic PCB

O. AC LED on, TEMP LED off, GAS LED on, Gas does not flow in SET mode using a hand torch or a machine torch without remote solenoid.

1. Defective gas solenoid (SOL1)
 - a) Measure voltage on Main Pcb between J5-1 to J5-3 for 12 VDC. If voltage is present, change SOL 1
2. Defective Logic Pcb
 - a) Measure on Main PCB between J2-12 to test point GND1 for 12VDC. If voltage is present, replace Main PCB.
3. Defective Main PCB
 - a) Replace Main PCB

P. AC LED on, TEMP LED off, GAS LED on, Gas does not flow in SET mode using a machine torch with remote solenoid.

Disconnect the gas solenoid SOL1 from the back of the ATC connector.

If Gas DOES NOT flow out of SOL1 when the unit is in SET mode :

1. Defective gas solenoid (SOL1)
 - a) Measure voltage on Main PCB between J5-1 to J5-3 for 12 VDC. If voltage is present, change SOL 1
2. Defective Logic PCB
 - a) Measure on Main PCB between J2-12 to test point GND1 for 12VDC. If voltage is present, replace Main PCB.

3. Defective Main PCB

- a) Replace Main PCB

If gas DOES flow out of SOL1 when the unit is in SET mode, reconnect SOL1 to the ATC connector.

4. Defective torch solenoid.
 - a) Measure the coil terminals of the torch mounted gas solenoid SOL2 for 24vac. If present, replace SOL2.
5. Defective Main PCB
 - a) Measure on Main PCB between J2-20 to GND1 for less than 2VDC.

If voltage is 12VDC replace Main PCB

- b) Measure on Main PCB between J2-11 to GND1 for less than 2VDC. If voltage is less than 2VDC replace Main PCB

6. Defective Logic PCB

- a) Measure on Main PCB between J2-11 to GND1 for less than 2VDC. If voltage is 12vdc, replace Logic PCB.

Q. Cannot adjust gas pressure in the SET mode

1. Inlet gas pressure is too low
 - a) Increase inlet gas pressure to 95-120 psi
2. Faulty regulator
 - a) Replace Regulator

5.09 Pilot Arc Problems

A. AC LED on, TEMP LED off, GAS LED on. Nothing happens when torch switch or remote switch is closed (Or CNC START signal is active) No gas flow, DC LED OFF.

1. Problem in the torch and leads switch circuit (or remote pendant or CNC signal missing)
 - a) For hand torches, Check continuity of torch switch circuit at ATC pins 3 & 4.
Negative / Plasma Lead

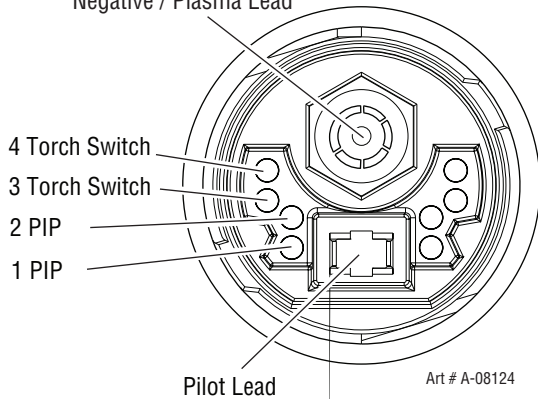

- b) For machine torches using a remote pendant, Check continuity of Pendant switch circuit
 - c) For CNC input see section "5.07 H Tip Missing Fault"
2. Defective Logic PCB
 - a) Jumper on Main PCB between J2-16 and test point GND1. If gas does not flow, replace Logic PCB
 - b) With Torch Switch closed, measure voltage on Main PCB between test points GND1 to I_DMD1 for 1.4VDC. Replace Logic PCB if voltage is not present.
3. Defective Main PCB 1
 - a) With Torch Switch closed, measure voltage on Main PCB between test points GND1 to I_DMD1 for 1.4 VDC. Replace Main PCB 1 if voltage is present.

B. SHORTED TORCH FAULT

After torch switch is closed, gas flows for two (2) seconds then momentarily shuts off then back on, FAULT INDICATOR flashes, and 85 PSI LED flashes.

1. Upper O-Ring on torch head is in the wrong position.
 - a) Remove shield cup from torch; check position of the upper o-ring and correct if needed.

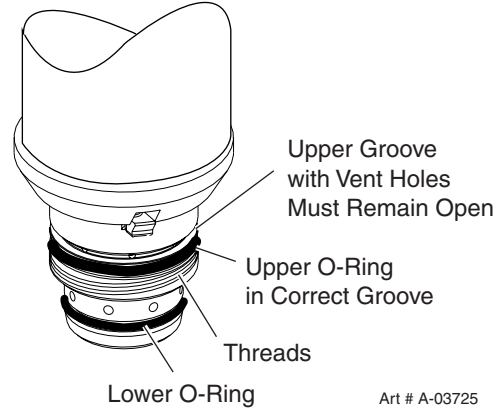

2. Torch start cartridge is stuck.
 - a) Turn off power supply. Bleed down the system. Remove the shield cup, tip, start cartridge and electrode. Check the lower end unit of the start cartridge for free movement. Replace the cartridge if the lower end unit does not move freely.

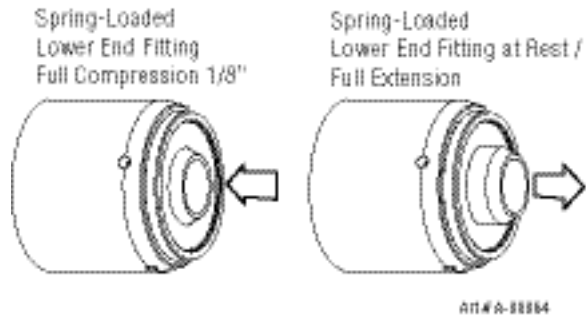

3. Worn or faulty torch parts
 - a) Inspect torch consumables parts. Replace if necessary.

4. Shorted Torch

- a) Disconnect torch from unit. With consumables removed from the torch, Check continuity of torch at ATC, between negative/plasma lead connection to pilot lead connection.

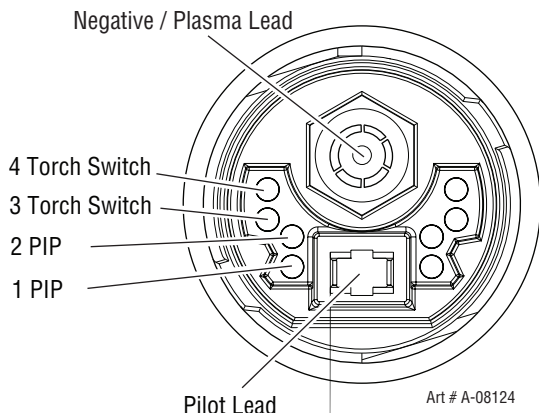

C. AC LED on, TEMP LED off, GAS LED on, gas flowing, DC LED off, Fault Indicators off, No arc in torch

- 1. Defective Logic PCB 3
 - a) Measure voltage at Main PCB between test point GND1 to J2-10.

Voltage is normally 12VDC and should drop to less than 2VDC two (2) seconds after torch switch is depressed. If voltage does not drop replace Logic PCB

- b) While pilot arc is established, measure voltage on Main PCB 1 between test points GND1 to I_DMD1 for 1.4 VDC. If voltage is low or not present, replace Logic PCB.
- 2. Defective Main PCB 1

- a) a) Measure voltage at Main PCB 1 between test point GND1 to J2-10.

Voltage is normally 12VDC and should drop to less than 2VDC two (2) seconds after torch switch is depressed. If voltage does not drop to less than 2VDC for approx one (1) second then replace Main PCB

D. AC LED on, TEMP LED off, GAS LED on, gas flowing, DC LED on, Fault Indicators off, No arc in torch.

- 1. Defective Main PCB 1
 - a) Install jumper on Main PCB 1 between test point GND1 to terminal TIP1.
 - b) Close torch switch. If Pilot starts, replace Main PCB

E. AC LED on, TEMP LED off, GAS LED on, gas flowing, DC LED on, Fault Indicators off, Pilot Arc is intermittent.

- 1. Defective Logic PCB
 - a) Measure for 12VDC on Main PCB between test Point GND1 to J2-8. If 12VDC is present, replace Logic PCB 3
- 2. Defective Main PCB 1
 - a) Replace Main PCB 1

F. INTERNAL ERROR FAULT INDICATOR AND 90 PSI INDICATOR FLASHING

- 1. There has been a microprocessor problem.
 - a) Turn ON/OFF SWITCH to OFF position and then turn to ON position to clear the error

5.10 Main Arc and Controls Problems

A. Main arc will not establish, LED D59 on Main PCB remains on while pilot arc is striking the work piece.

- 1. Work Cable not connected.
 - a) Connect cable to work piece
- 2. Work cable open / broken.
 - a) Check continuity of work cable. Insure connection of cable to clamp is secure.

B. Main arc transfers but current cannot be adjusted

- 1. Defective Logic PCB 3
 - a) While main arc is transferred, measure voltage on Main PCB between test points GND1 to I_DMD1.
 - b) Adjust CURRENT CONTROL POTENTIOMETER from maximum to minimum. Voltage should vary from 4VDC at max to 1 VDC at min

If voltage does not vary with CURRENT CONTROL POTENTIOMETER, Replace Logic PCB

- 2. Defective Main PCB 1
 - a) Replace Main PCB 1

C. In LATCH mode, when the torch switch is released the arc shuts off immediately.

- 1. Defective Logic PCB 3
 - a) Replace Logic PCB 3.

F. In RAPID AUTO RESTART mode, with torch switch closed, the pilot does not start immediately when the cutting arc extinguishes

1. Defective Logic PCB
 - a) Replace Logic PCB

G. INTERNAL ERROR FAULT INDICATOR AND 90 PSI INDICATOR FLASHING

1. There has been a microprocessor problem.
 - a) Turn ON/OFF SWITCH to OFF position and then turn to ON position to clear the error

5.11 CNC Interface Problems

A. Nothing happens when jumper is installed between J2-3 to J2-4.

1. Defective Automation Interface PCB 4
 - a) Measure voltage on PCB4 between J1-6 to J1-8 for 12VDC.

If 12VDC is present replace PCB 4

2. Defective Main PCB 1
 - a) Measure voltage on MAIN PCB between J1-6 to J1-8 for less than 2VDC.

If voltage is less than 2VDC, replace PCB 1

B. No OK-TO-MOVE signal while cutting.

1. Defective MAIN Pcb 1
 - a) Measure voltage on PCB 4 between J1-1 to J1-3 for 12VDC while cutting.

If 12VDC is present, replace MAIN PCB 1

2. Defective Automation Interface PCB 4
 - a) Measure voltage on PCB4 between J1-1 to J1-3 for less than 2VDC while cutting.

If voltage is less than 2VDC, replace PCB 4.

C. ARC VOLTS signals are low or not present

1. Defective Automation Interface PCB (PCB4)
 - a) Replace PCB4

5.12 Test Procedures

A. Main Contactor (W1) Test

1. Check continuity between:
 - L1 to T1
 - L2 to T2
 - L3 to T3
 - L4 to T4

The contacts should be open – no continuity.

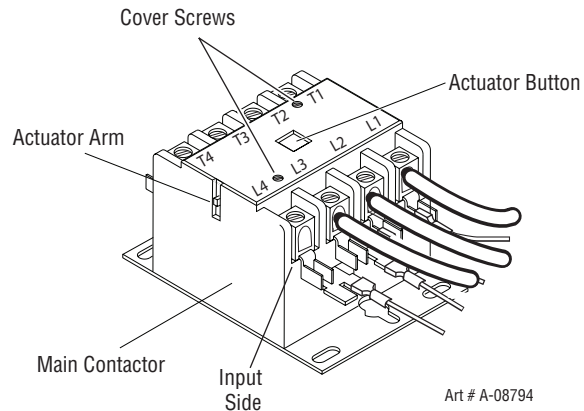

2. Retest continuity between terminals while engaging the contacts manually. This can be done by pushing down on the recessed actuator button on the top of W1 or pushing down on the actuator arm on the side of W1.

- L1 to T1
- L2 to T2
- L3 to T3
- L4 to T4

The contacts should be closed – Continuity

3. Visually check W1 contact points. To take the cover off, remove the two cover screws shown in the previous illustration. Replace if contacts are stuck together or show excessive arcing

B. Input Diode Module Test

- Using an ohmmeter perform the tests in the chart

Input Diode Module		
Meter (+)	Meter (-)	Indication
AC1	MTH 2	Forward Bias
AC2	MTH 2	Forward Bias
AC3	MTH 2	Forward Bias
MTH 2	AC1	Reverse Bias
MTH 2	AC2	Reverse Bias
MTH 2	AC3	Reverse Bias
MTH 5	AC1	Forward Bias
MTH 5	AC2	Forward Bias
MTH 5	AC3	Forward Bias
AC1	MTH 5	Reverse Bias
AC2	MTH 5	Reverse Bias
AC3	MTH 5	Reverse Bias

- If the test reveals a failed component, replace Main PCB and perform main contactor test – Section 5.11A

C. Input Capacitor PCB Test

- Using an ohmmeter check continuity between the following points:

Input Capacitors		
Meter +	Meter -	Indication
MTH 2	MTH 4	Charging
MTH 4	MTH 5	Open
MTH 6	MTH 5	Charging

Most meters will show a charging action. Initially a low resistance will be shown and then the resistance will start to increase. If the meter probes are reversed the reading will decrease to zero, then start charging in the opposite polarity.

- If a short is found replace Capacitor PCB assembly.

- Check continuity between the following points

Input relays		Indication
MTH 2	MTH 6	Open
MTH 4	MTH 6	Open
MTH 4	MTH 5	Open

- If a short is found, replace Capacitor PCB assembly

D. IGBT Modules Test

- Disconnect transformer wires from Main PCB 1 terminals PRI 1 (A) and PRI 4 (D).
- Using an ohmmeter perform the following checks

IGBT A		
Meter (+)	Meter (-)	Indication
PRI 1 (A)	MTH 2	Forward Bias
PRI 1 (A)	MTH 4	Reverse Bias
MTH 2	PRI 1 (A)	Reverse Bias
MTH 4	PRI 1 (A)	Forward Bias
PRI 2 (B)	MTH 2	Forward Bias
PRI 2 (B)	MTH 4	Reverse Bias
MTH 2	PRI 2 (B)	Reverse Bias
MTH 4	PRI 2 (B)	Forward Bias

IGBT B		
Meter (+)	Meter (-)	Indication
PRI 3 (C)	MTH 6	Forward Bias
PRI 3 (C)	MTH 5	Reverse Bias
MTH 6	PRI 3 (C)	Reverse Bias
MTH 5	PRI 3 (C)	Forward Bias
PRI 4 (D)	MTH 6	Forward Bias
PRI 4 (D)	MTH 5	Reverse Bias
MTH 6	PRI 4 (D)	Reverse Bias
MTH 5	PRI 4 (D)	Forward Bias

- If the test reveals a failed component, replace Main Pcb and perform main contactor test – Section 5.11A. If no problem is found, reconnect the transformer wires to Main PCB 1

CUTMASTER 20mm

E. Output Diode Module Test

1. Disconnect transformer wires from Main PCB terminal SEC 1.
2. Using an ohmmeter perform the tests in the chart

Output Diode Module		
Meter (+)	Meter (-)	Indication
SEC 1	WORK 1	Forward Bias
SEC 1	CHOKE 1	Reverse Bias
WORK 1	SEC 1	Reverse Bias
CHOKE 1	SEC 1	Forward Bias
SEC 2	WORK 1	Forward Bias
SEC2	CHOKE 1	Reverse Bias
WORK 1	SEC2	Reverse Bias
CHOKE 1	SEC 2	Forward Bias

3. If the test reveals a failed component, replace Main Pcb. If no problem is found, reconnect the transformer wires to Main PCB.

F. Pilot IGBT Test

1. Disconnect wire from Main PCB terminal TIP1
2. Measure continuity on Main PCB between test point GND1 to terminal TIP1
3. If the test reveals a failed component, replace Main PCB. If no problem is found, reconnect wire to Main PCB.

Signal Information

Many of the signal listed will be low voltage signals that will be in one of two states: +12VDC (High) or 0VDC (Low) with respect to pcb common.. When a signal name is preceded by the “/” mark, it denotes that the signal is an active low. For example:

/OVERTEMP – This signal is normally High but when an over temperature fault exists, this line will change state to a Low.

5.13 Capacitor PCB Layout & Signals

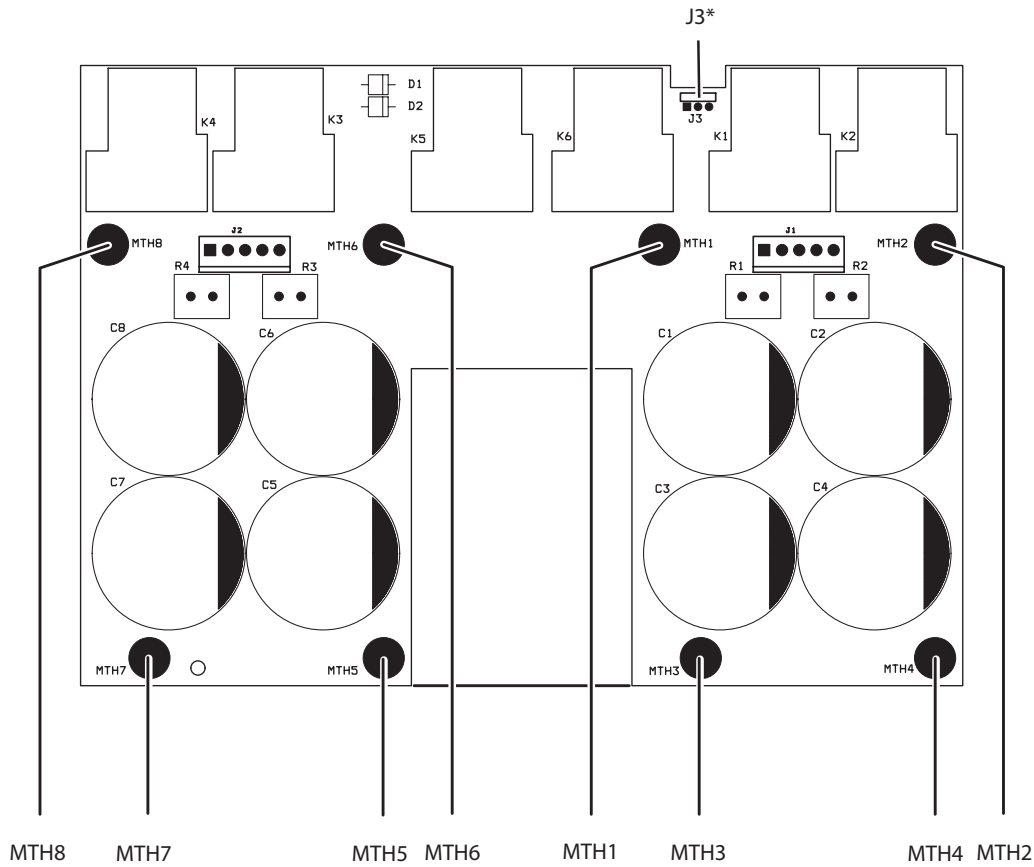

Art # A-08841

*J3 CONNECTOR PINOUT

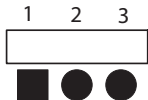

CAPACITOR PCB 2 LAYOUT

A. CAPACITOR PCB SIGNALS

J1-1 Capacitor bank A+

J1-5 Capacitor bank A-

J2-1 Capacitor Bank B+

J2-5 Capacitor Bank B-

Signal Source-Destination

J3-1	+12 VDC	M-C
J3-2	/460 Active low for 460VAC input	M-C
J3-3	/230 Active low for 230VAC input	M-C

B. CAPACITOR PCB TEST POINTS

MTH1,2	Capacitor bank A+
MTH3,4	Capacitor bank A-
MTH6,8	Capacitor Bank B+
MTH 5,7	Capacitor Bank B-

5.14 Logic PCB Layout & Signals

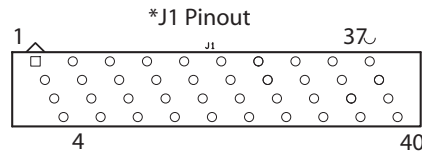
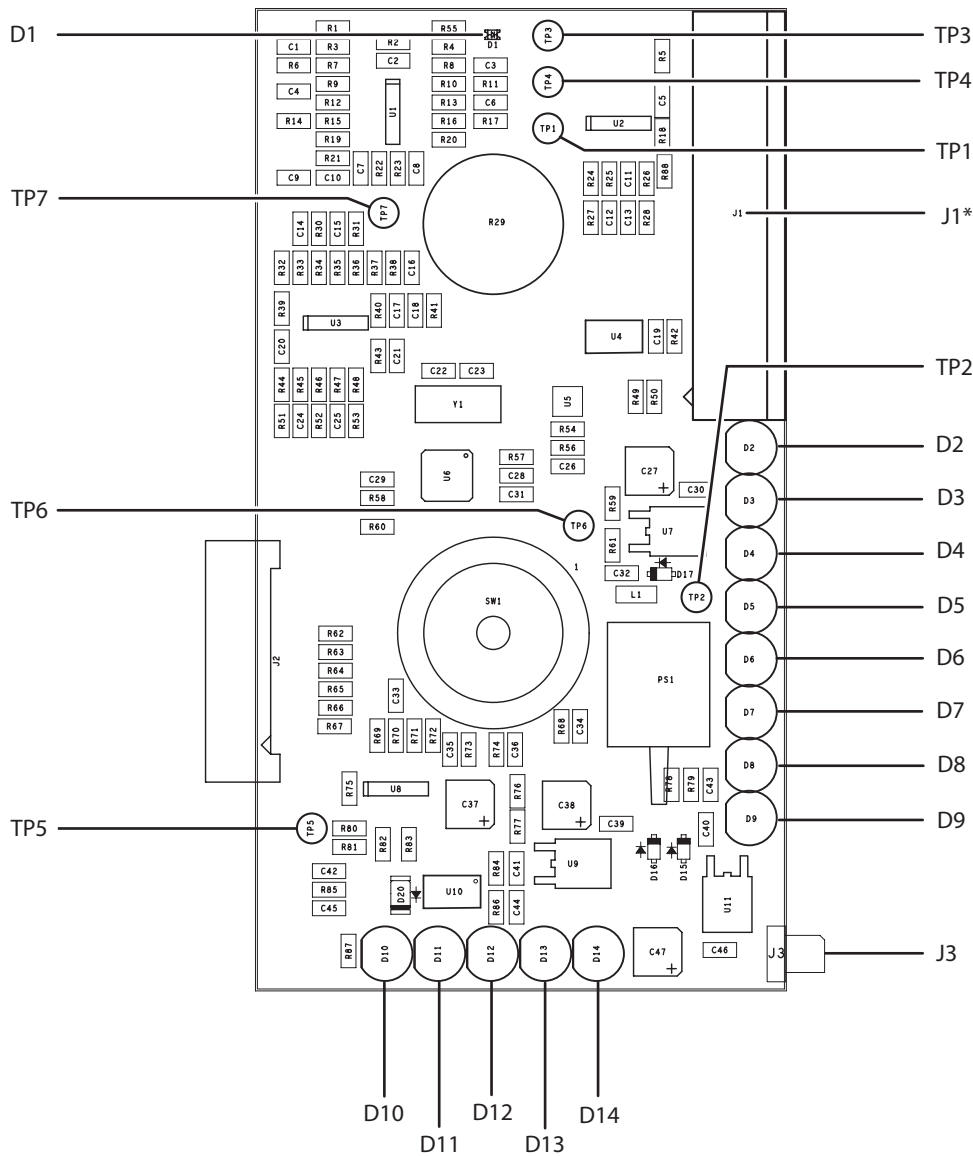

Art # A-08504_AB

LOGIC PCB LAYOUT

A. LOGIC PCB SIGNALS

(Same for MAIN PCB J2)

Signal Source/Destination

Signal	Description	Signal Source/Destination
J1-1	-VOUT (-) OUTPUT VOLTAGE	M-L
J1-2	/TIP VOLTS Active high when tip is installed	M-L
J1-3	TIP_SEN Approx. 100VDC while cutting with tip not in contact w/work piece, Active low when tip contact work during cut (Drag Mode)	M-L
J1-4	/400V_IN Active low with 400vac primary input voltage	L-M

J1-5	N/A		
J1-6	CUR_SET	Current demand signal. Variable 1-4VDC	L-M
J1-7	/RAR	Active low when in Rapid Auto Restart mode	L-M
J1-8	/INRUSH	Active low after inrush time expires	L-M
J1-9	/W1_ON	Active low to enable W1 contactor	L-M
J1-10	SHDN	Active low enables PWM circuit	
J1-11	/TRCH_SOL	Active low to enable Torch Solenoid	L-M
J1-12	/SOL_ON	Active low to enable Power Supply solenoid	L-M
J1-13	/OK_TO_MOVE	Active low to enable OK_TO_MOVE (CNC)	L-M
J1-14	/FAN_ON	Active low to enable fans	L-M
J1-15	/LATCH_ACTIVE	Active low when Latch mode is active during cut	L-M
J1-16	/TRCH_SW	Active low = START is active -Torch switch, CNC	M-L
J1-17	/PIP	Active low = PARTS IN PLACE satisfied	M-L
J1-18	AC_ON	Pulse signal	M-L
J1-19	CSR	Active high during main transfer	M-L
J1-20	/TORCH_SOL_DETECTED	Active low for torch with remote solenoid	M-L
J1-21	/OVERTEMP	Active low when over temperature	M-L
J1-22	V_IN	Input Voltage signal 2.6VDC = 400 VAC	M-L
J1-23	+12VDC		M-L
J1-24	+12VDC		M-L
J1-25	GND		M-L
J1-26	GND		M-L
J1-27	Not Used		
J1-28	Not Used		
J1-29	MAIN_BD_ID	Voltage level to identify Main PCB = 1.7VDC	M-L
J1-30	Not Used		
J1-31	Not Used		
J1-32	Not Used		
J1-33	Not Used		
J1-34	For Factory Use		M-L
J1-35	For Factory Use		M-L
J1-36	For Factory Use		M-L
J1-37	For Factory Use		M-L
J1-38	GND		M-L
J1-39	For Factory Use		M-L
J1-40	Not Used		

CUTMASTER 20mm

B. LOGIC PCB LED INDICATORS

<u>NORMAL INDICATION</u>	<u>FIRMWARE VERSION</u>	<u>ERROR MESSAGE</u>	
D1	+12VDC		
D2	MAX PRESSURE	X.7	Over Pressure
D3	90 PSI	X.6	Internal Error
D4	85 PSI	X.5	Shorted torch
D5	80 PSI	X.4	Tip Missing
D6	75 PSI	X.3	Start Signal active during power up
D7	70 PSI	X.2	Parts-In-Place Fault (PIP)
D8	65 PSI	X.1	Input Power Fault
D9	MIN PRESSURE	X.0	Low Pressure
D10	AC	1.X	
D11	OVERTEMP	2.X	
D12	GAS	3.X	
D13	DC	4.X	
D14	ERROR	5.X	

C. LOGIC PCB TEST POINTS

TP1	Common
TP2	+12VDC
TP3	+5VDC
TP4	+3.3DCV
TP5	0.5 to 5 VDC / 0 - 100 psi
TP6	+1.8VDC
TP7	Potentiometer Current Demand (0-3.3VDC)

This Page Intentionally Blank

5.15 Main PCB Layout & Signals

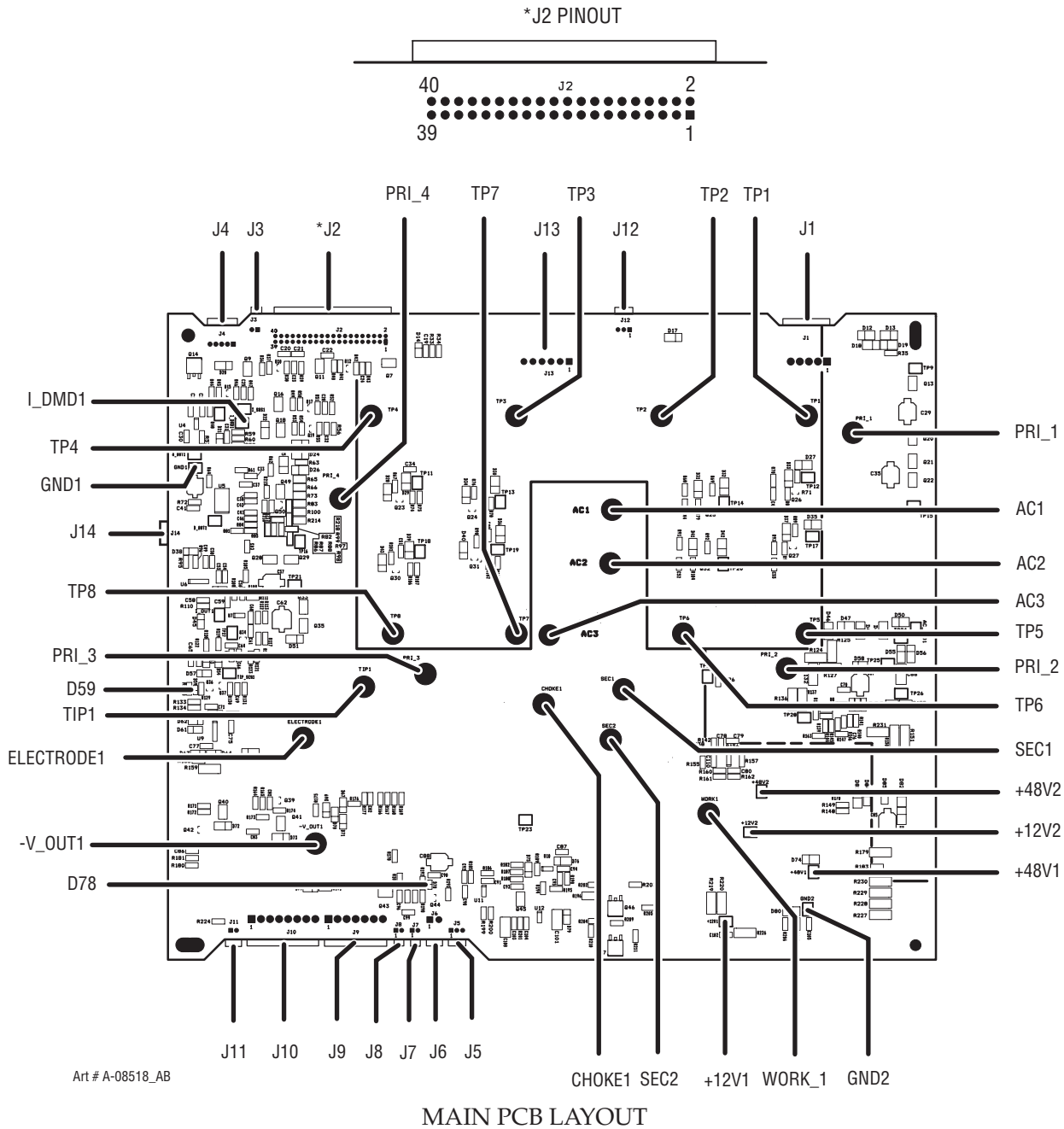

A. MAIN PCB SIGNALS

J1-1	L1 Primary AC Line
J1-2	Not used
J1-3	Not used
J1-4	Not used
J1-5	L2 Primary AC Line
J2	Signal info is the same as Logic PCB 3 connector J1

J3-1	/230VAC
J3-2	Common
J4-1	3.3VDC
J4-2	TXD
J4-3	RXD
J4-4	Common
J4-5	D
J5-1	+12VDC
J5-2	Not used
J5-3	/SOLENOID
J6-1	24VAC Supply for W1
J6-2	24VAC Return
J7-1	+12VDC
J7-2	/FAN
J8-1	+12VDC
J8-2	/FAN
J9-1	/PIP
J9-2	Common
J9-3	/TORCH SWITCH (Start)
J9-4	Common
J9-5	Torch solenoid 24VAC supply
J9-6	Not Used
J9-7	Torch solenoid 24VAC return
J10-1	/OK-TO-MOVE
J10-2	Not used
J10-3	/OK-TO-MOVE
J10-4	Not used
J10-5	Common
J10-6	Common
J10-7	Not used
J10-8	/START (Torch Switch)
J11-1	Jumper installed
J11-2	Jumper installed

J12-1	+12VDC
J12-2	/460VAC
J12-3	/230VAC

B. LED INDICATORS

D59 PCRIndicates Pilot IGBT gate signal is on
D78 CSRIndicates cutting arc has been established

C. MAIN PCB TEST POINTS

GND1	Common
GND2	Common
GND3	Common
+12V1	+12VDC
+48V1	+48VDC
I_DMD10	4VDC Current Demand Signal

5.16 Main PCB Wiring Diagram

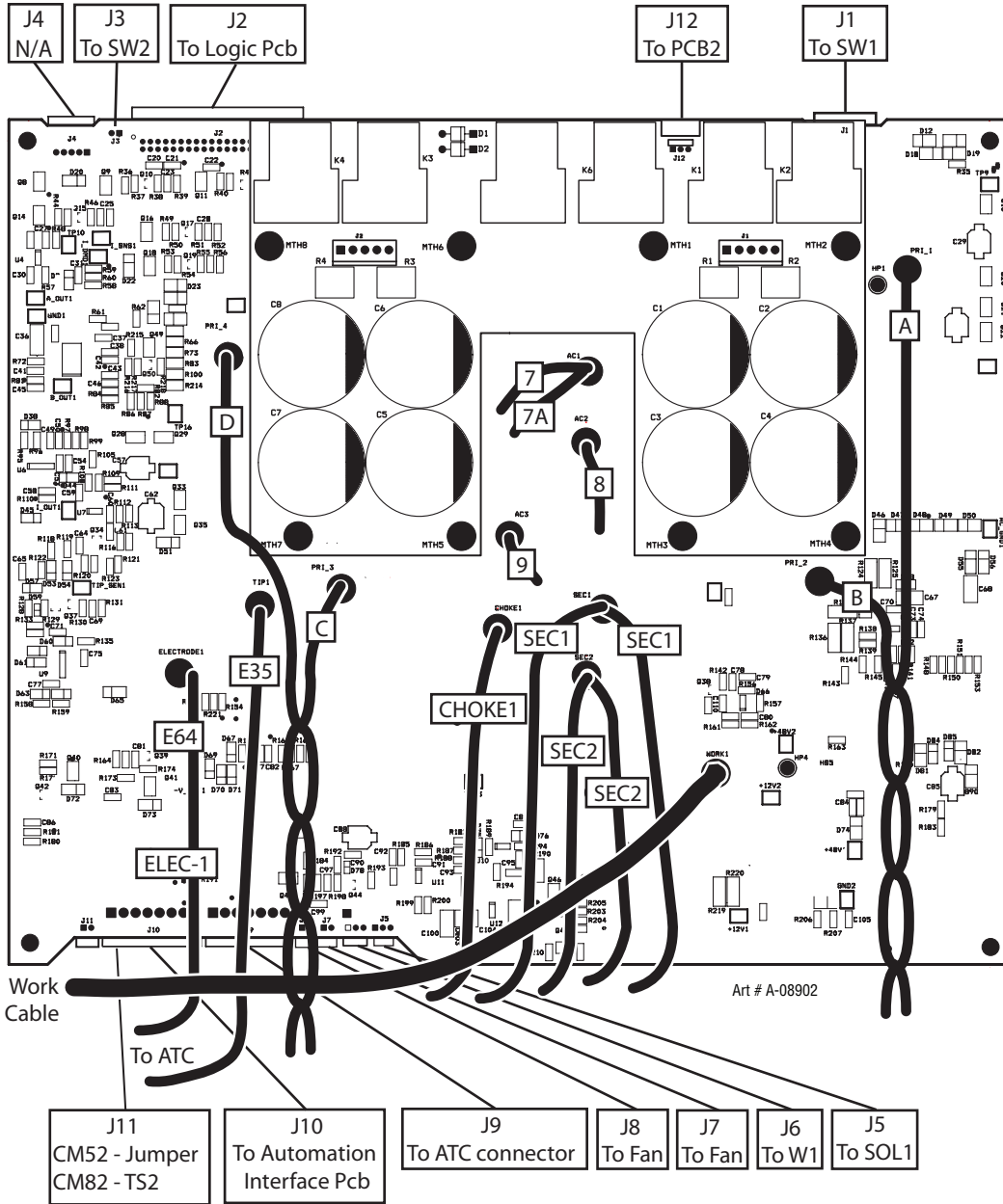

MAIN PCB WIRING DIAGRAM

SECTION 5 TORCH: SERVICE

It is recommended to apply a very light film of o-ring lubricant (Catalog # 8-4025) to the o-rings on a weekly basis.

5T.01 General Maintenance

NOTE

Refer to Previous "Section 5 System" for common and fault indicator descriptions.

Cleaning Torch

Even if precautions are taken to use only clean air with a torch, eventually the inside of the torch becomes coated with residue. This buildup can affect the pilot arc initiation and the overall cut quality of the torch.



WARNINGS

Disconnect primary power to the system before disassembling the torch or torch leads.

DO NOT touch any internal torch parts while the AC indicator light of the Power Supply is ON.

The inside of the torch should be cleaned with electrical contact cleaner using a cotton swab or soft wet rag. In severe cases, the torch can be removed from the leads and cleaned more thoroughly by pouring electrical contact cleaner into the torch and blowing it through with compressed air.



CAUTION

Dry the torch thoroughly before reinstalling.

O-Ring Lubrication

An o-ring on the Torch Head and ATC Male Connector requires lubrication on a scheduled basis. This will allow the o-rings to remain pliable and provide a proper seal. The o-rings will dry out, becoming hard and cracked if the lubricant is not used on a regular basis. This can lead to potential performance problems.

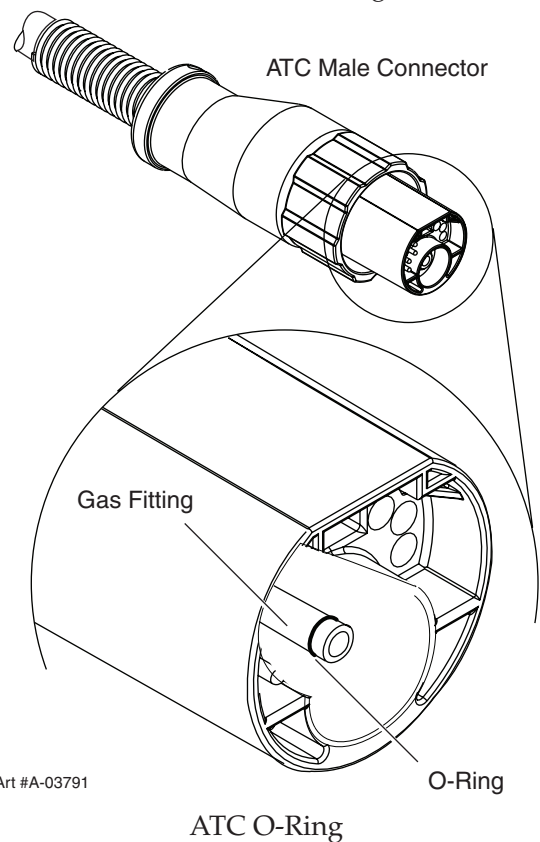
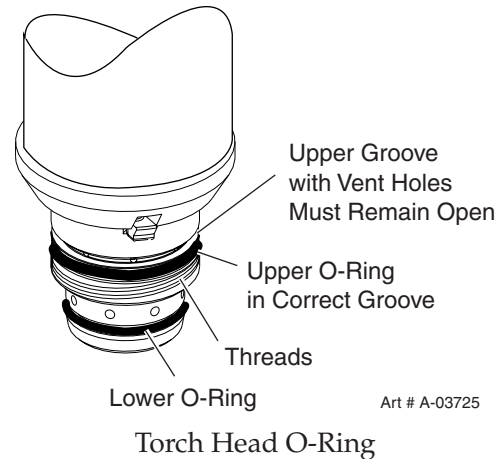

NOTE

DO NOT use other lubricants or grease, they may not be designed to operate within high temperatures or may contain "unknown elements" that may react with the atmosphere. This reaction can leave contaminants inside the torch. Either of these conditions can lead to inconsistent performance or poor parts life.

5T.02 Inspection and Replacement of Consumable Torch Parts



WARNINGS

Disconnect primary power to the system before disassembling the torch or torch leads.

DO NOT touch any internal torch parts while the AC indicator light of the Power Supply is ON.

Remove the consumable torch parts as follows:

NOTE

The shield cup holds the tip and starter cartridge in place. Position the torch with the shield cup facing upward to prevent these parts from falling out when the cup is removed.

1. Unscrew and remove the shield cup from the torch.

NOTE

Slag built up on the shield cup that cannot be removed may effect the performance of the system.

2. Inspect the cup for damage. Wipe it clean or replace if damaged.

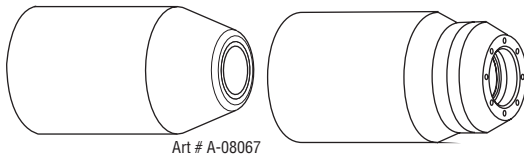

Art # A-08067

Shield Cups

3. On torches with a shield cup body and a shield cap or deflector, ensure that the cap or deflector is threaded snugly against the shield cup body. In shielded drag cutting operations (only), there may be an O-ring between the shield cup body and drag shield cap. Do not lubricate the O-ring.

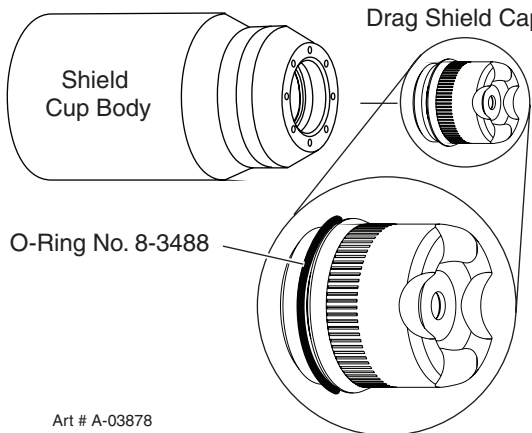

Art # A-03878

4. Remove the tip. Check for excessive wear (indicated by an elongated or oversized orifice). Clean or replace the tip if necessary.

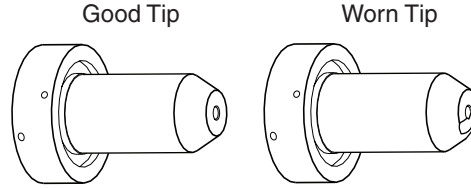

A-03406

Example of Tip Wear

5. Remove the starter cartridge. Check for excessive wear, plugged gas holes, or discoloration. Check the lower end fitting for free motion. Replace if necessary.

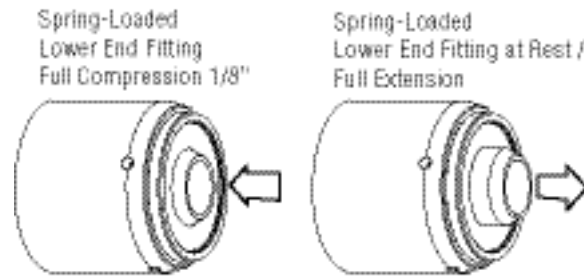

Art # A-88864

6. Pull the Electrode straight out of the Torch Head. Check the face of the electrode for excessive wear. Refer to the following figure.

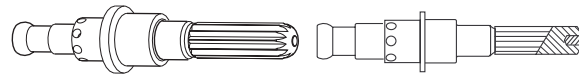

New Electrode

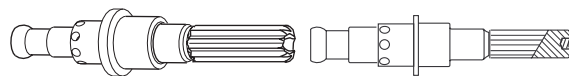

Worn Electrode

Art # A-03284

Electrode Wear

7. Reinstall the Electrode by pushing it straight into the torch head until it clicks.
8. Reinstall the desired starter cartridge and tip into the torch head.
9. Hand tighten the shield cup until it is seated on the torch head. If resistance is felt when installing the cup, check the threads before proceeding.

This completes the parts replacement procedures.

SECTION 6: PARTS LISTS

6.01 Introduction

A. Parts List Breakdown

The parts list provide a breakdown of all replaceable components. The parts lists are arranged as follows:

- Section 6.03 Complete Power Supply Replacement
- Section 6.04 Major External Replacement Parts
- Section 6.05 Front Panel Replacement Parts
- Section 6.06 Left Side Replacement Parts
- Section 6.07 Right Side Replacement Parts
- Section 6.08 Options and Accessories
- Section 6.09 Replacement Parts for Hand Torch
- Section 6.10 Replacement Parts - for Mechanized Torches with Unshielded Leads
- Section 6.11 Torch Consumable Parts Manual and Mechanized Torches

NOTE

Parts listed without item numbers are not shown, but may be ordered by the catalog number shown.

B. Returns

If a product must be returned for service, contact your distributor. Materials returned without proper authorization will not be accepted.

6.02 Ordering Information

Order replacement parts by catalog number and complete description of the part or assembly, as listed in the parts list for each type item. Also include the model and serial number of the power supply. Address all inquiries to your authorized distributor.

6.03 Power Supply Replacement

The following items are included with the replacement power supply: work cable & clamp, input power cable, gas pressure regulator / filter, and operating manual.

Qty	Description	Catalog #
1	CutMaster 20mm Non CE Power Supply With 380/400/415VAC 3 phase, 50/60 Hz input power cable	3-1130-3
1	CutMaster 20mm CE Power Supply with 380/400/415VAC 3 phase, 50/60 Hz input power cable	3-1130-4

CUTMASTER 20mm

6.04 Major External Replacement Parts

Item #	Qty	Description	Catalog #
1	1	Cover with labels	9-0221
2	1	Base Enclosure Assembly	9-0118
3	1	Tube, roll handle	9-0121
4	1	Front Panel	9-0227
5	1	Rear Panel	9-0101

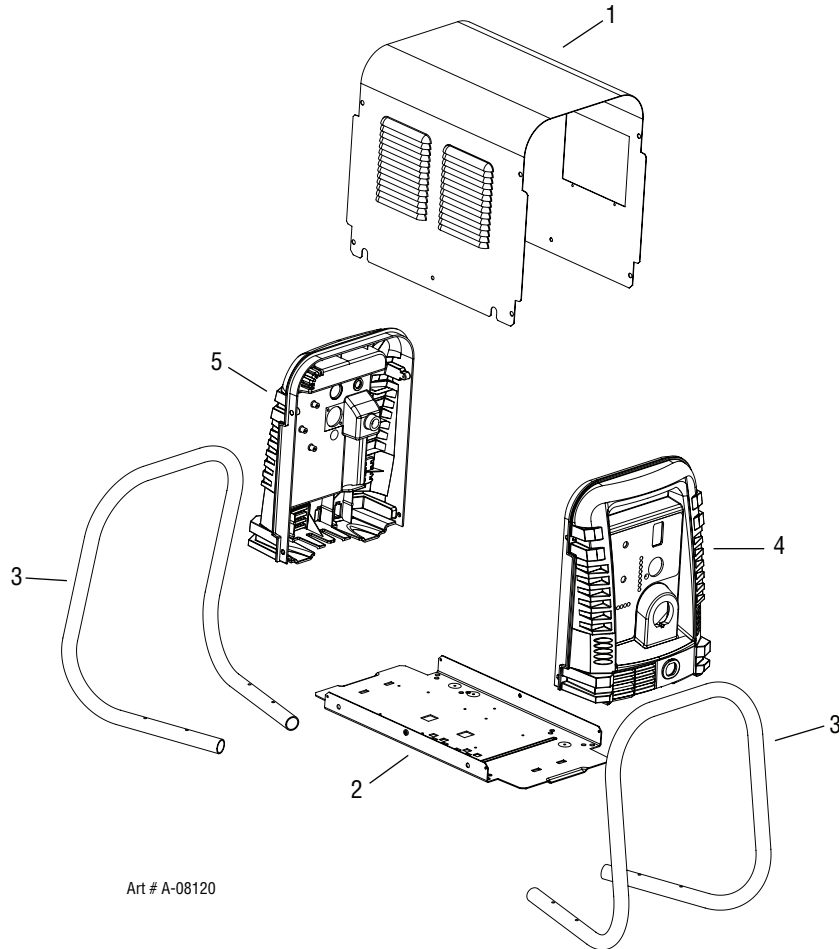

NOTE

Illustration may vary slightly from unit.

6.05 Front Panel Replacement Parts

Item#	Qty	Description	Ref.	Catalog #
1	1	Output Current Control and Function Control Knobs		9-8527
2	1	Toggle - On/Off Switch	SW1	9-0109
3	1	Work Cable with Clamp, 20 Ft / 6.1 m		9-0184
Not Shown:	1	Wire harness (from SW1) w/EMI Choke (CE Power Supplies Only)		9-0247

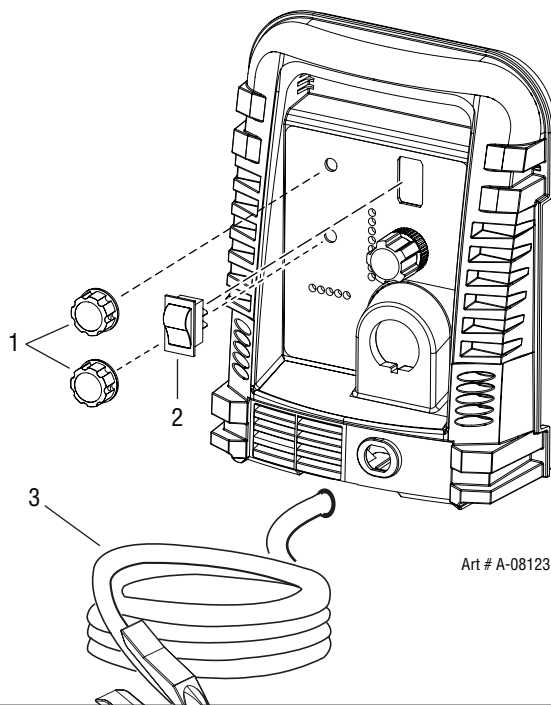

NOTE

Illustration may vary slightly from unit.

CUTMASTER 20mm

6.06 Left Side Replacement Parts

Item #	Qty	Description	Ref	Catalog #
1	1	Main PCB Assembly	PCB1	9-0108
2	1	Logic PCB	PCB3	9-0107*
3	1	Center Chassis Molded Plastic		9-0102
4	1	Fan,	MOT1,MOT2	9-0104
5	1	Transformer, Main	T1	9-0106
6	1	Inductor, Output	L1	9-0105
Not Shown:				
	1	Power Cable Strain Relief, for all units		9-0111
	1	Input Power Cord for 380/400/415V Power Supply		9-0218

NOTE:

*9-0107 Logic PCB, If the serial number of the power supply is prior to #05078755 then kit number 9-0201 will be needed to replace not only the Logic PCB (9-0107) but the regulator (9-0115) as well. Another way to tell if the kit is needed is to see if the regulator has a small diameter tube coming out of the bottom fitting. If there is a transducer and wire harness instead of the tube, the kit is not needed.

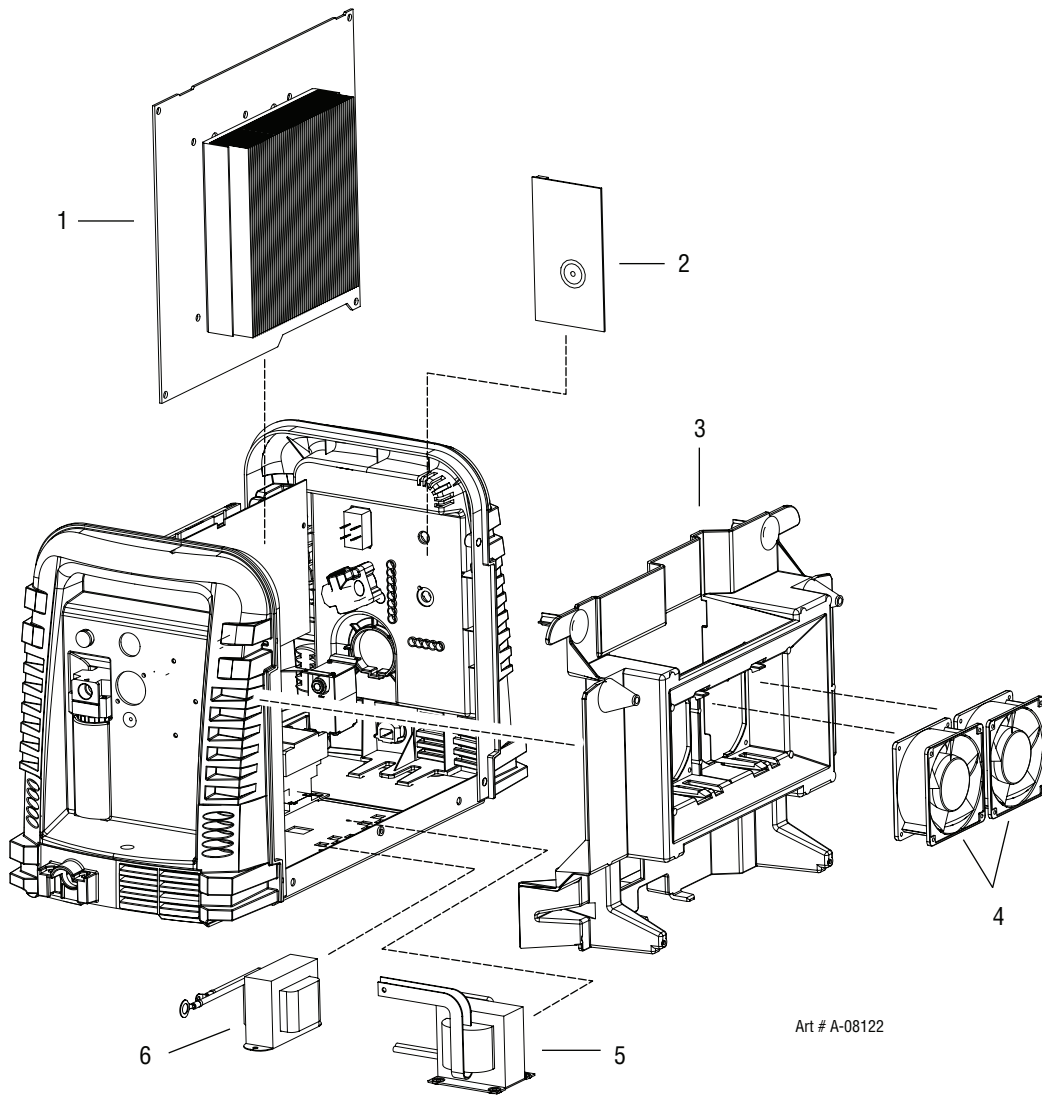

NOTE

Illustration may vary slightly from unit.

6.07 Right Side Replacement Parts

Item #	Qty	Description	Ref	Catalog #
1	1	Contactora, 4 Pole	W1	9-8587
2	1	Solenoid, 12V	SOL1	9-0114
3	1	Spare Parts Box		7-3267
4	1	Spare Parts Box Cover		7-3266
5	1	Console Quick Disconnect </td <td></td> <td>9-0161</td>		9-0161
6	1	Regulator, with knob and mounting nut		9-0115*
7	1	Assembly, PCB, Input Capacitors	PCB2	9-0167
8	1	Filter, Auto Drain		9-0116

NOTE:

*9-0115 regulator, If the serial number of the power supply is prior to #05078755 then kit number 9-0201 will be needed to replace not only the regulator (9-0115) but the logic PCB as well. Another way to tell if the kit is needed is to see if the regulator has a small diameter tube coming out of the bottom fitting. If there is a transducer and wire harness instead of the tube, the kit is not needed.

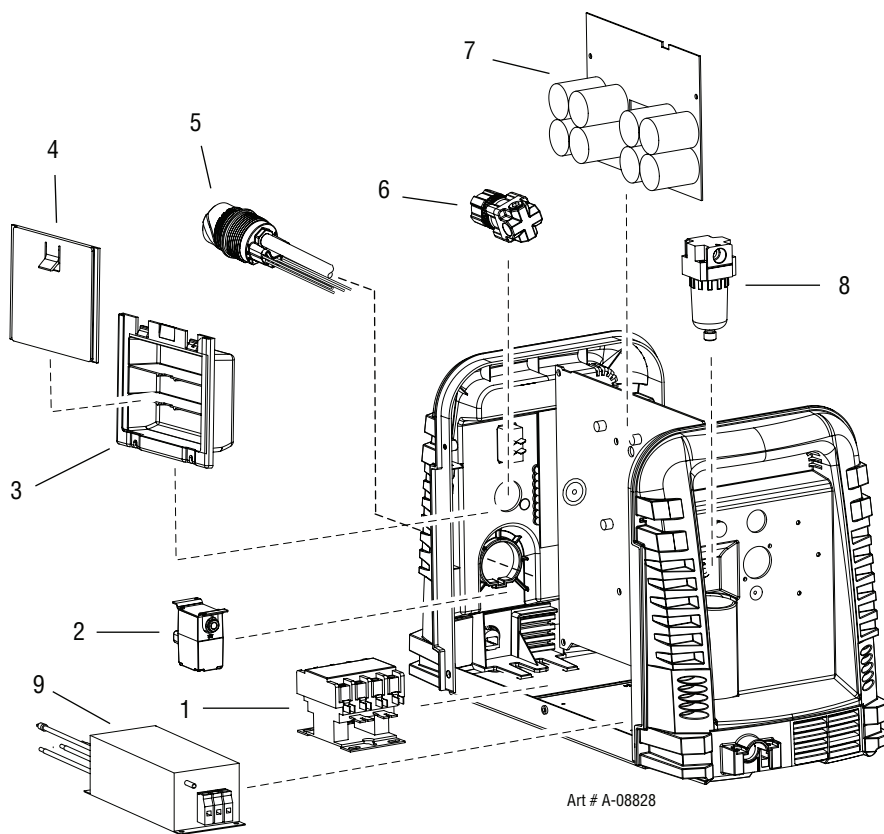

NOTE

Illustration may vary slightly from unit.

6.08 Options and Accessories

Qty	Description	Catalog #
1	Single - Stage Filter Kit (includes Filter & Hose)	7-7507
1	Replacement Filter Body	9-7740
1	Replacement Filter Hose (not shown)	9-7742
2	Replacement Filter Element	9-7741
1	Two - Stage Filter Kit (includes Hose & Mounting Screws Bracket, Filter Mounting (not shown)	9-9387
1	Two - Stage Air Filter Assembly	9-7527
1	First Stage Cartridge	9-1021
1	Second Stage Cartridge	9-1022
1	Extended Work Cable (50 ft / 15.2 m) with Clamp	9-8529
1	Multi - Purpose Cart	7-8888
1	Automation Interface Kit	9-8310
1	25' / 7.6 m CNC Cable for Automation Interface Kit	9-8312
1	50' / 15.2 m CNC Cable for Automation Interface Kit	9-8313
1	Nylon Dust Cover	9-7071

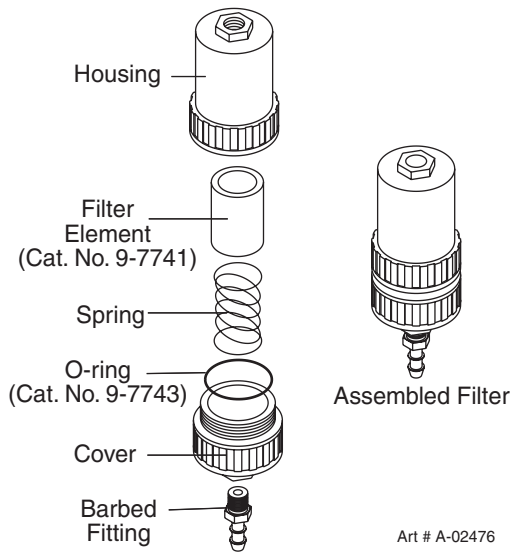

Optional Single - Stage Filter Kit

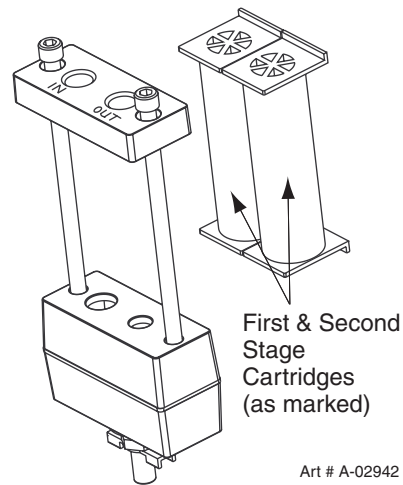

Optional Two - Stage Filter Kit

6.09 Replacement Parts for Hand Torch

Item #	Qty	Description	Catalog #
1	1	Torch Handle Replacement Kit (includes items No. 2 & 3)	9-7030
2	1	Trigger Assembly Replacement Kit	9-7034
3	1	Handle Screw Kit (5 each, 6-32 x 1/2" cap screw, and wrench)	9-8062
4	1	Torch Head Assembly Replacement Kit (includes items No. 5 & 6)	9-8219
5	1	Large O - Ring	8-3487
6	1	Small O - Ring	8-3486
7		Leads Assemblies with ATC connectors (includes switch assemblies)	
	1	SL60, 20 - foot Leads Assembly with ATC connector	4-7834
	1	SL60, 50 - foot Leads Assembly with ATC connector	4-7835
	1	SL100, 20 - foot Leads Assembly with ATC connector	4-7836
	1	SL100 , 50 - foot Leads Assembly with ATC connector	4-7837
8	1	Switch Kit	9-7031
10	1	Torch Control Cable Adapter (includes item # 11)	7-3447
11	1	Through - Hole Protector	9-8103

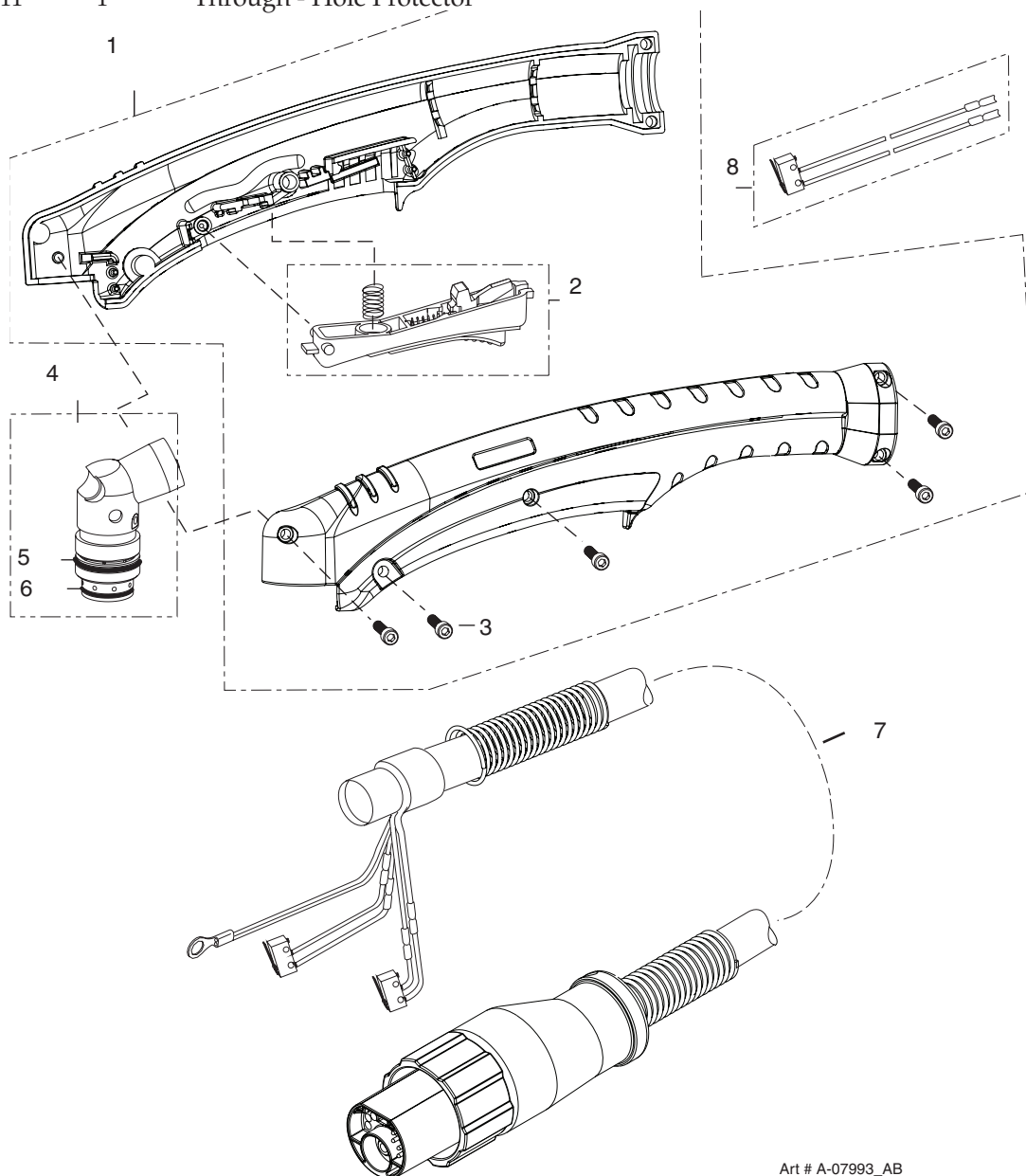

Art # A-07993_AB

CUTMASTER 20mm

6.10 Replacement Parts - for Mechanized Torches with Unshielded Leads

Item No.	Qty	Description	Catalog No.
1	1	Torch Head Assembly without leads (includes items 2, 3, and 14)	9-8220
2	1	Large O - Ring	8-3487
3	1	Small O - Ring	8-3486
4	1	PIP Switch Kit	9-7036
5		Unshielded Automated Leads Assemblies with ATC connectors	
	1	5 - foot / 1.5 m Leads Assembly with ATC connector	4-7850
	1	10 - foot / 3.05 m Leads Assembly with ATC connector	4-7851
	1	25 - foot / 7.6 m Leads Assembly with ATC connector	4-7852
	1	50 - foot / 15.2 m Leads Assembly with ATC connector	4-7853
6		Unshielded Mechanized Leads Assemblies with ATC connectors	
	1	5 - foot / 1.5 m Leads Assembly with ATC connector	4-7842
	1	10 - foot / 3.05 m Leads Assembly with ATC connector	4-7843
	1	25 - foot / 7.6 m Leads Assembly with ATC connector	4-7844
	1	50 - foot / 15.2 m Leads Assembly with ATC connector	4-7845
7	1	11" / 279 mm Rack	9-7041
8	1	11" / 279 mm Mounting Tube	9-7043
9	1	End Cap Assembly	9-7044
10	2	Body, Mounting, Pinch Block	9-4513
11	1	Pin, Mounting, Pinch Block	9-4521
12	1	Torch Holder Sleeve	7-2896
13	1	PIP Plunger and Return Spring Kit	9-7045
	1	Pinion Assembly (Not shown)	7-2827
	1	5" / 126 mm Positioning Tube (Not shown)	9-7042

NOTE

* Does not include Control Cable Adapter or Through - Hole Protector.

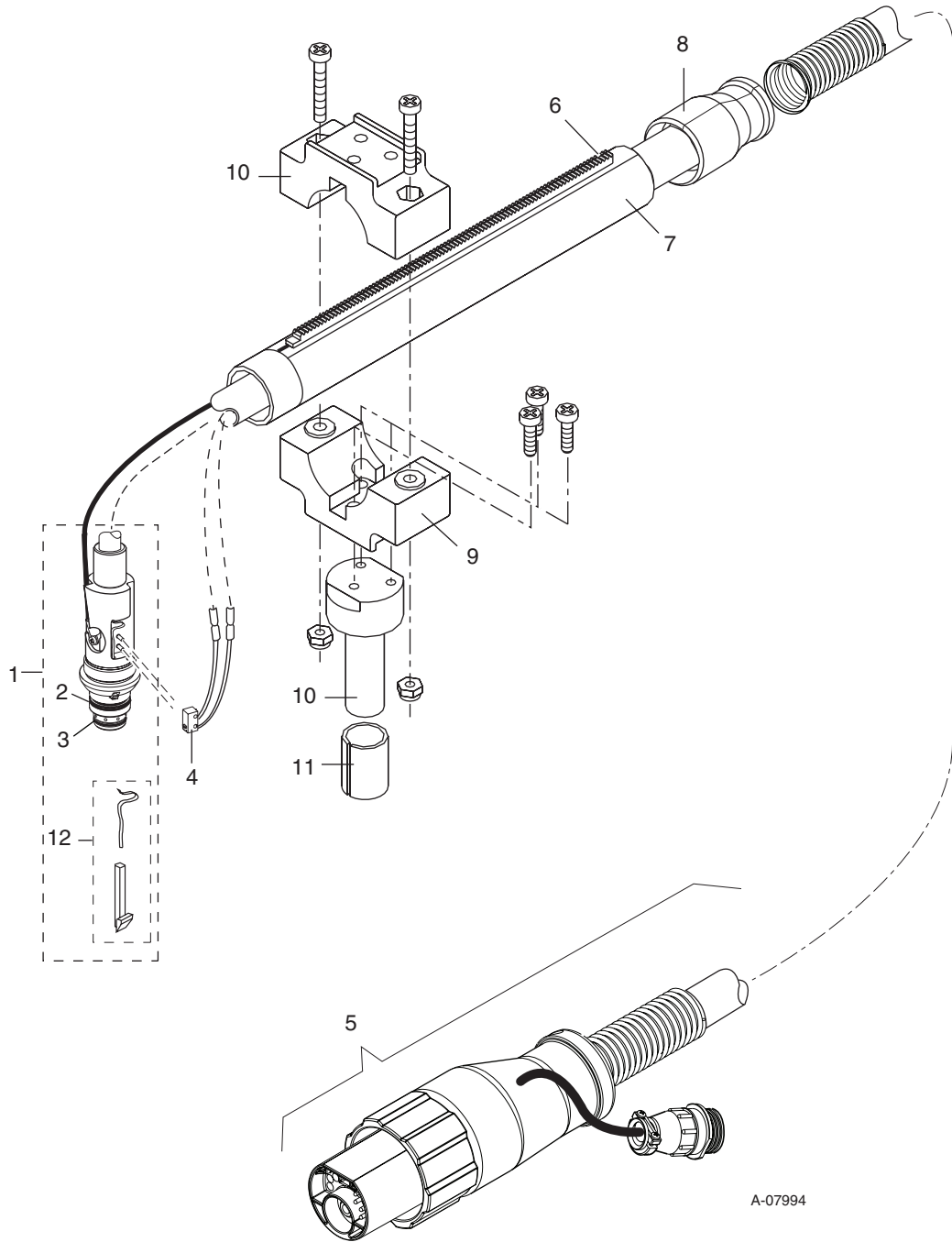

A-07994

6.11 Torch Consumable Parts Manual and Mechanized Torches

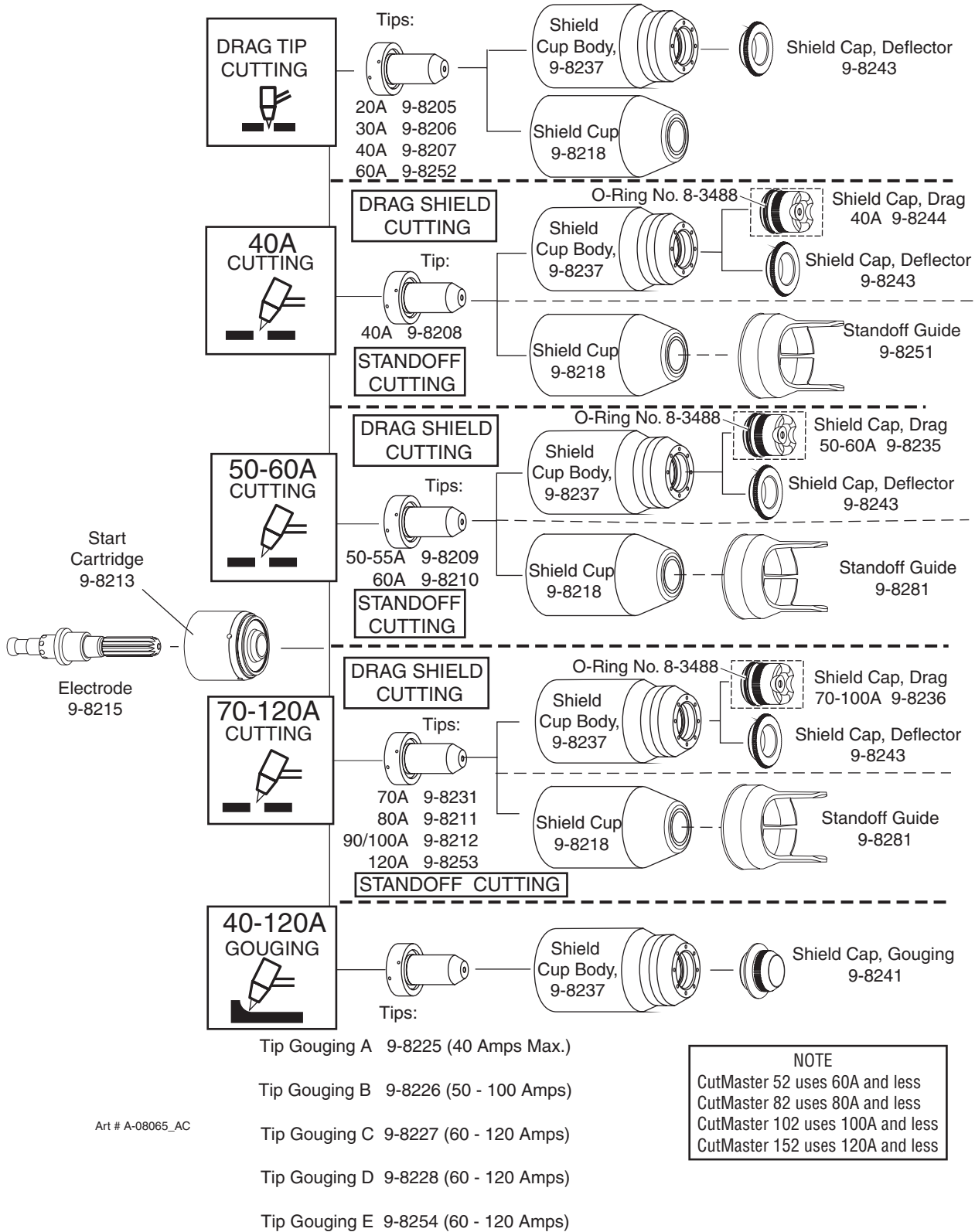

SECTION 7: REPLACEMENT PROCEDURES

7.01 Scope

This section describes parts replacement procedures which may be performed on the CutMaster 20mm Power Supply.

Under no circumstances are field repairs to be attempted on Printed Circuits or other subassemblies of this unit. Evidence of unauthorized repairs may void the factory warranty.

7.02 Anti-Static Handling Procedures

A. General



Caution

PC Boards can be irreparably damaged by improper handling due to electrostatic discharge (ESD).

Replacement PC Boards are shipped in a protective enclosure to prevent damage from electrostatic discharge (ESD) during shipping. A ground strap is included with each replacement board to prevent static damage during installation.



WARNINGS

Read and understand these instructions and the instructions on the grounding wrist strap package before opening the equipment enclosure or removing the replacement PC board from its protective enclosure.

Disconnect primary power to the system before disassembling the torch, torch leads, or power supply enclosure.

Where these instructions include specific torquing instructions, failure to torque properly will cause component damage.

Do not operate the equipment or test equipment under power while wearing the grounding wrist strap.

B. Procedure

1. Open the wrist strap and unwrap the first two folds of the band. Wrap the adhesive side firmly around your wrist.
2. Unroll the rest of the band and peel the liner from the copper foil at the opposite end.
3. Attach the copper foil to a convenient and exposed electrical ground.
4. Connect the equipment primary cable ground to the same electrical ground as the wrist strap.
5. Open the equipment enclosure and remove the failed PC board.
6. Carefully open the ESD protective bag and remove the replacement PC Board.
7. Install the replacement PC Board in the equipment and make all necessary connections.
8. Place the failed PC Board in the ESD protective bag and seal for return shipping.
9. Replace the power supply cover.
10. Remove the grounding wrist strap from your wrist and from the electrical ground connection before reconnecting primary power to the equipment.

7.03 Parts Replacement - General Information

The parts replacement procedures described in this manual, except for filter replacement, require that the Power Supply be disassembled. The part to be replaced will determine to what extent the Power Supply must be disassembled.

Before removing any connection mark each wire with the connection designation. When reassembling make sure the wires go to the proper terminals.

Note the routing of wires and make sure the wires are put back in the same place when re-assembling the unit.

Each subsection is referenced to Section 6 for parts lists and overall detailed drawings.



WARNING

Disconnect primary power from the source before opening or disassembling the power supply.

7.04 Major External Parts

A. Cover Removal

Tools required: T20 Torx Driver

1. Remove the upper and lower screws which secure the cover to the main assembly. Do not loosen the lower screws inside the cut out slots in the bottom of the cover.

Note

The upper screws and lower screws are not the same. Do not mix them. The upper screws are for threading into the plastic of the front and rear panels. DO NOT use the finer threaded lower screws for this.

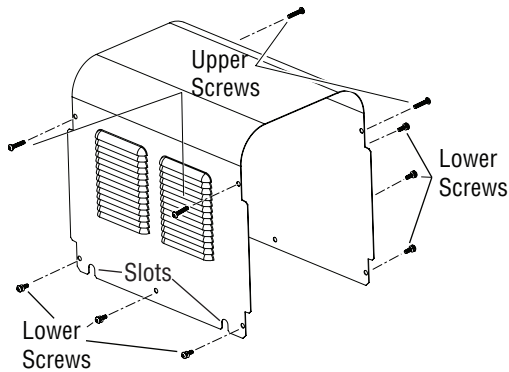

Art # A-07947

2. Carefully pull the Cover up and away from the unit.

B. Cover Installation

1. Reverse previous procedures for cover installation.

NOTE

When installing the upper screws, attempt to reuse the original threads. The easiest way to do this is by turning the screw counter-clockwise until you feel the threads line up, then begin to turn the screw clockwise to tighten. Do not over tighten.

C. Tube Handle Replacement

Tools required: T20 Torx Driver

1. Disconnect the Torch and Leads from the unit.
2. Remove the cover per subsection 7.04 A.
3. Remove the screws securing the tube handles to the base of the unit.

NOTE

Some of the earliest manufactured units have Tube Handles that are joined together under the base of the unit. Later versions are not joined together.

4. Remove the power supply from the Tube Handles.
5. Replace the Tube Handles by reversing the above steps.
6. Reinstall the power supply cover.

D. Disconnecting Front and Rear Panels from the base

In many of the replacement procedures, it may be helpful to disconnect the front or rear panel from the base in order to allow more room to access the parts.

Tools required: T20 Torx Driver

1. Remove the cover per subsection 7.04 A.
2. For earlier models remove the Tube Handles per subsection 7.04 C. The earlier model Tube Handles join together under the base. Later models do not and there is enough room to perform this procedure without removing them.
3. While grasping the panel close to the base, pull the panel directly from the base to release the locking tabs.
4. To re-engage the panel, position the panel so that the locking tabs are above the base, then push the panel back onto the base until the locking tabs engage the mating holes in the base.
5. For complete removal of panel, disconnect any other item still attached to the panel and another component of the power supply.

7.05 Front Panel Parts Replacement

Refer to section 6.05 for Front Panel Replacement Parts and overall detailed drawing.

A. Current Control Potentiometer (A) Knob Replacement

Tools required: Flat Screw Driver

1. Turn the potentiometer fully clockwise and note the location of the pointer mark on the knob.
2. Loosen the screw securing the Current Control Knob to the potentiometer shaft and remove the knob.
3. Replace the knob on the potentiometer shaft with the pointer in the same position as noted in step 1.

B. Function Control Switch Knob Replacement

Tools required: Flat Screw Driver

1. Turn the Function Control Switch until the pointer on the knob is in the LATCH position.
2. Loosen the screw securing the knob to the switch shaft and remove the knob.
3. Replace the knob on the switch shaft with the pointer in the position noted in step 1.

C. Replacing Gas Hoses

Tools required: T20 Torx Driver

1. Remove the cover per subsection 7.04A
2. Push the gas fitting locking ring back. A small open end wrench works well for this.

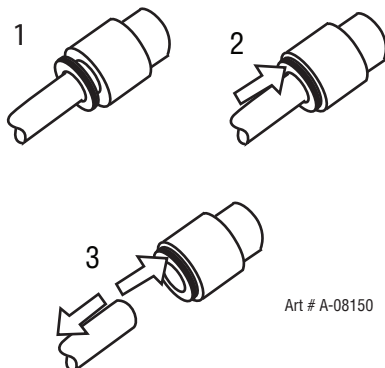

3. Pull the hose from the fitting.
4. Replace the hose by pushing the hose back into the fitting until it fully seats. Check it by pulling on the hose. If done correctly it will not pull out.
5. Reinstall the power supply cover

D. Air Regulator Replacement

Tools required: T20 Torx Driver

1. Remove the cover per subsection 7.04A
2. Remove the three (3) air hoses from the regulator per subsection 7.05-C
3. Pull the Air Regulator adjusting knob from the shaft.
4. Loosen and remove the locking nut securing the Air Regulator to the front Panel, then remove the regulator.
5. Install replacement Air Regulator by reversing the above steps.
6. Reinstall the power supply cover

E. Gas Solenoid Replacement

Tools required: T20 Torx Driver, Flat Screw Driver

1. Remove the cover per subsection 7:04A
2. Disconnect J5 connector from the Main PCB.
3. Remove the air hose from Gas Solenoid per subsection 7.05-C
4. The Solenoid utilizes the same type locking fitting as the gas hoses. Using a flat blade screw driver, push the locking ring towards the Solenoid while pulling the Solenoid away from the ATC.
5. Install the replacement Gas Solenoid by reversing the above steps
6. Reinstall the power supply cover

F. Logic PCB (PCB3) Replacement

Tools required: T20 Torx Driver Flat Screw Driver, ½" wrench

1. Remove the cover per subsection 7.04A
2. Remove the two large and one small gas hoses from the pressure regulator per subsection 7.05C.
3. Unplug the connector J2 from the Main PCB.
4. Remove the Current Control Potentiometer Knob and nut securing the potentiometer shaft to the front panel per subsection 7.05A
5. Remove the Function Control Switch Knob and the nut securing the switch shaft to the front panel per subsection 7.05B.
6. Pull the top of the front panel forward slightly and carefully remove the Logic PCB from the unit.

7. Install the replacement Logic PCB by reversing the above steps.
8. Reinstall the power supply cover.

G. ON/OFF Switch (SW1) Replacement

Tools required: T20 Torx Driver

1. Remove the cover per subsection 7.04A
2. Disconnect the wires on the rear of the switch, noting the location and orientation of each wire as shown below.

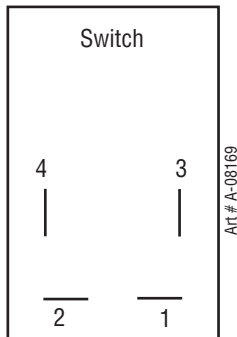

3. Squeeze together the clips on the back of the switch, then remove the switch through the front panel.
4. Install the replacement switch by reversing the above steps.
5. Reinstall the power supply cover

H. Work Cable Replacement

Tools required: T20 Torx Driver

1. Remove the Cover per subsection 7.04A.
2. Disconnect the work cable from the WORK1 terminal on the Main PCB.
3. Squeeze the top and bottom of the Work Cable Strain Relief and remove from the front panel.
4. Install the replacement Work Cable by reversing the above steps.
5. Reinstall the power supply cover

7.06 Left Side Internal Parts Replacement

A. Fan Replacement

Tools required: T20 Torx Driver

1. Remove the Cover per subsection 7.04A
2. Unplug J7 and J8 connectors from Main PCB.
3. Carefully feed the fan wires through the center chassis wire slot.
4. Remove the fan by pushing the fan retaining clips apart and pulling the fan out of the center chassis.
5. On the replacement fan(s) note the direction of air flow as labeled on the fan housing and orient so fan will blow air into the unit.
6. Install replacement fan by reversing the above steps.
7. Reinstall the power supply cover

B. Main Transformer (T1) Replacement

Tools required: T20 Torx Driver, 1/2" Nut Driver

1. Remove the Cover per subsection 7.04A
2. Remove the Tube Handle per subsection 7.04C
3. Remove the two large and one small gas hoses per subsection 7.05C
4. Remove the Gas Solenoid per subsection 7.05E
5. Disconnect the transformer wires from terminals PRI 1 (A), PRI 2 (B), PRI 3 (C), PRI 4 (D), SEC1, SEC2 on the Main PCB.
6. Disconnect J2 & J3 connectors from Main PCB.
7. Remove the two screws securing the Center Chassis to the base.
8. Loosen the two screws on the Input Power Cable strain relief.
9. Disengage the Rear panel from the base per section 7.04D.
10. Guide the rear panel back six (6) inches away from the base.
11. Guide the Center Chassis towards the center of the base to disengage the bottom locking tabs securing the Chassis to the base.
12. Carefully guide the Center Chassis up far enough to lay the Chassis down to the right side of the unit.

13. Remove the two screws securing the Main Transformer to the base.
14. Remove the Main Transformer, carefully guiding all its wires through from the right side of the unit.
15. Install replacement Transformer by reversing the above steps.
16. Reinstall the power supply cover

C. Output Inductor (L1)

Tools required: T20 Torx Driver, ½" Nut Driver

1. Remove the Cover per subsection 7.04A
2. Remove the Tube Handle per subsection 7.04C
3. Remove the two large and one small gas hoses per subsection 7.05-C
4. Remove the Gas Solenoid per subsection 7.05-E
5. Disconnect J2 & J3 connectors from Main PCB.
6. Disconnect Output Inductor wire from terminal Choke1 on the Main PCB.
7. Disconnect Output inductor wire from ATC connector.
8. Remove the two screws securing the Center Chassis to the base.
9. Loosen the two screws on the Input Power Cable strain relief.
10. Disengage the Rear panel from the base per section 7.04D.
11. Guide the rear panel back six (6) inches away from the base.
12. Guide the Center Chassis towards the center of the base to disengage the bottom locking tabs securing the Chassis to the base.
13. Carefully guide the Center Chassis up far enough to lay the Chassis down towards the right side of the unit.
14. Remove the two screws securing the Output Inductor to the base.
15. Remove the Output Inductor, carefully guiding its wires through from the right side of the unit.
16. Install replacement Output Inductor by reversing the above steps.
17. Reinstall the power supply cover.

7.07 Rear Panel Parts Replacement

A. Filter Element Assembly Replacement

The Filter Element Assembly is in the rear panel. For better system performance, the filter element should be checked per the Maintenance Schedule (Subsection 5.02), and either cleaned or replaced.

1. Remove power from the power supply; turn off the gas supply and bleed down the system.
2. Remove the system cover. See "A Cover Removal" in this section.
3. Locate the internal air line and the fitting from the filter assembly. Number 1 in the following illustration.
4. Hold a wrench or similar tool against the locking ring on the filter assembly fitting, then pull on the hose to release it. (Numbers 2 and 3 in the following illustration).

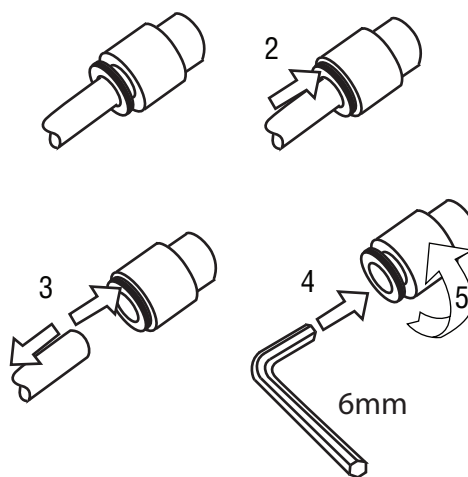
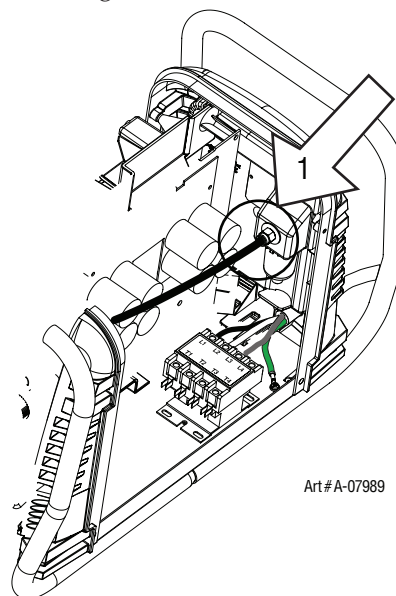

5. Remove the fitting from the filter element assembly by inserting a 6 mm hex wrench into the internal hex fitting and turning it counter clock-wise (left). Numbers 4 and 5 in the previous illustration.
6. Disconnect the input line from the filter element assembly.
7. Remove the filter element assembly through the rear opening.

NOTE

If replacing or cleaning just the filter element refer to the following illustration for disassembly.

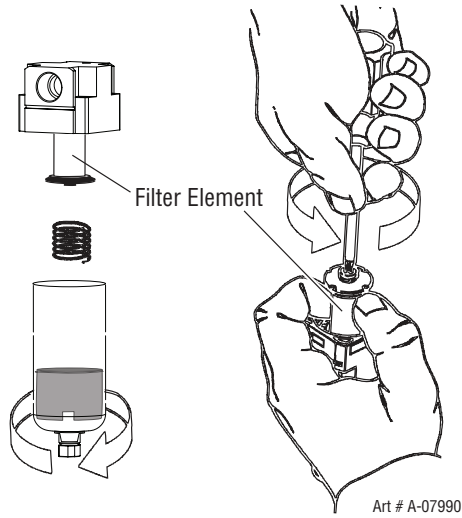

8. Install the new or cleaned assembly by reversing these procedures.
9. Turn on the air supply and check for leaks before reinstalling the cover.
- 10.. Reinstall the power supply cover

B. Optional Single-Stage Filter Element Replacement

These instructions apply to power supplies where the optional Single-Stage Filter has been installed.

The Power Supply shuts down automatically when the Filter Element becomes completely saturated. The Filter Element can be removed from its housing, dried, and reused. Allow 24 hours for Element to dry. Refer to Section 6, Parts List, for replacement filter element catalog number.

1. Remove power from power supply.
2. Shut off air supply and bleed down system before disassembling Filter to change Filter Element.
3. Disconnect gas supply hose.
4. Turn the Filter Housing Cover counter-clockwise and remove it. The Filter Element is located inside the Housing.

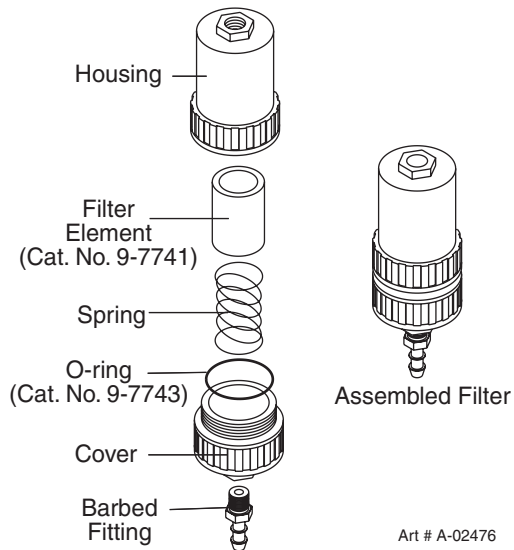

Optional Single-Stage Filter Element Replacement

5. Remove the Filter Element from the Housing and set Element aside to dry.
6. Wipe inside of housing clean, then insert the replacement Filter Element open side first.
7. Replace Housing on Cover.
8. Reattach gas supply.
9. Reinstall the power supply cover

NOTE

If unit leaks between housing and cover, inspect the "O" Ring for cuts or other damage.

7.08 Right Side Internal Parts Replacement

A. Capacitor PCB (PCB2) Replacement

Tools required: T20 Torx Driver

1. Remove the Cover per subsection 7.04A
2. Remove the eight screws securing PCB2 to the Main PCB.
3. Install the replacement PCB by reversing the above steps.

B. Main PCB (PCB1) Replacement

Tools required: T20 Torx Driver

1. Remove the Cover per subsection 7.04A
2. Remove the two large gas hoses per subsection 7.05-C
3. Remove the Gas Solenoid per subsection 5.05E
4. Remove Capacitor PCB per subsection 7.08 A.
5. Disconnect the wires and connectors from the PCB, noting the location and orientation of each wire and connector.
6. Remove the four (4) mounting screws securing the PCB to the center chassis.
7. Carefully guide the PCB assembly up and out of the unit.
8. Install the replacement PCB by reversing the above steps.
9. Reinstall the power supply cover

C. Main Contactor (W1) Replacement

Tools required: T20 Torx Driver

1. Remove the Cover per subsection 7.04A
2. Remove all wires from W1, noting the location and orientation of each wire
3. Loosen the two (2) Torx head screws securing the Main Contactor to the base.
4. Slide the contactor towards the rear of the unit slightly to allow the contactor to clear the mounting screws.
5. Lift Main Contactor up and out of the unit.
6. Install the replacement Contactor by reversing the above steps.
7. Reinstall the power supply cover.

This Page Intentionally Blank

APPENDIX 1: SEQUENCE OF OPERATION (BLOCK DIAGRAM)

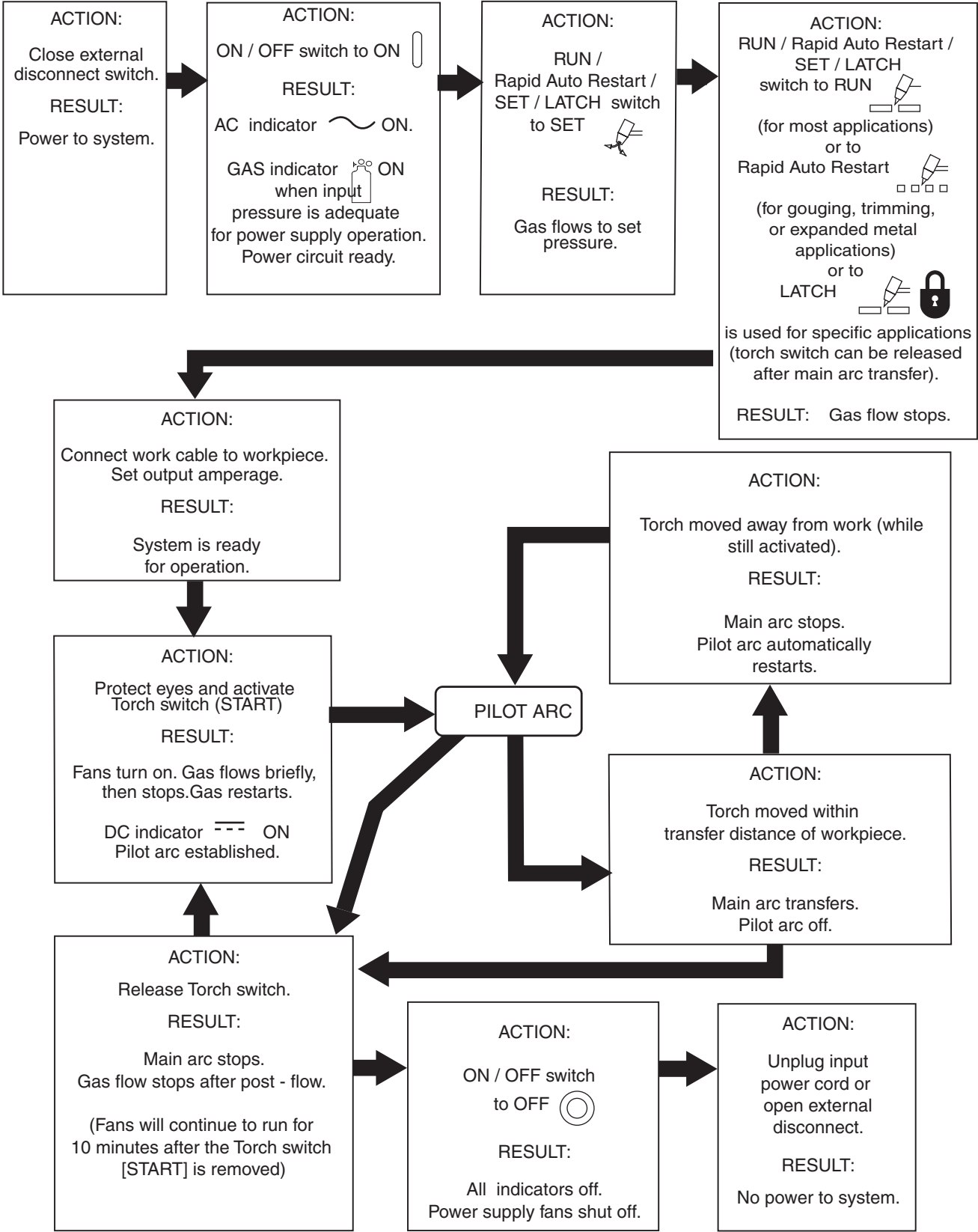

Art #A-08793

APPENDIX 2: DATA TAG INFORMATION

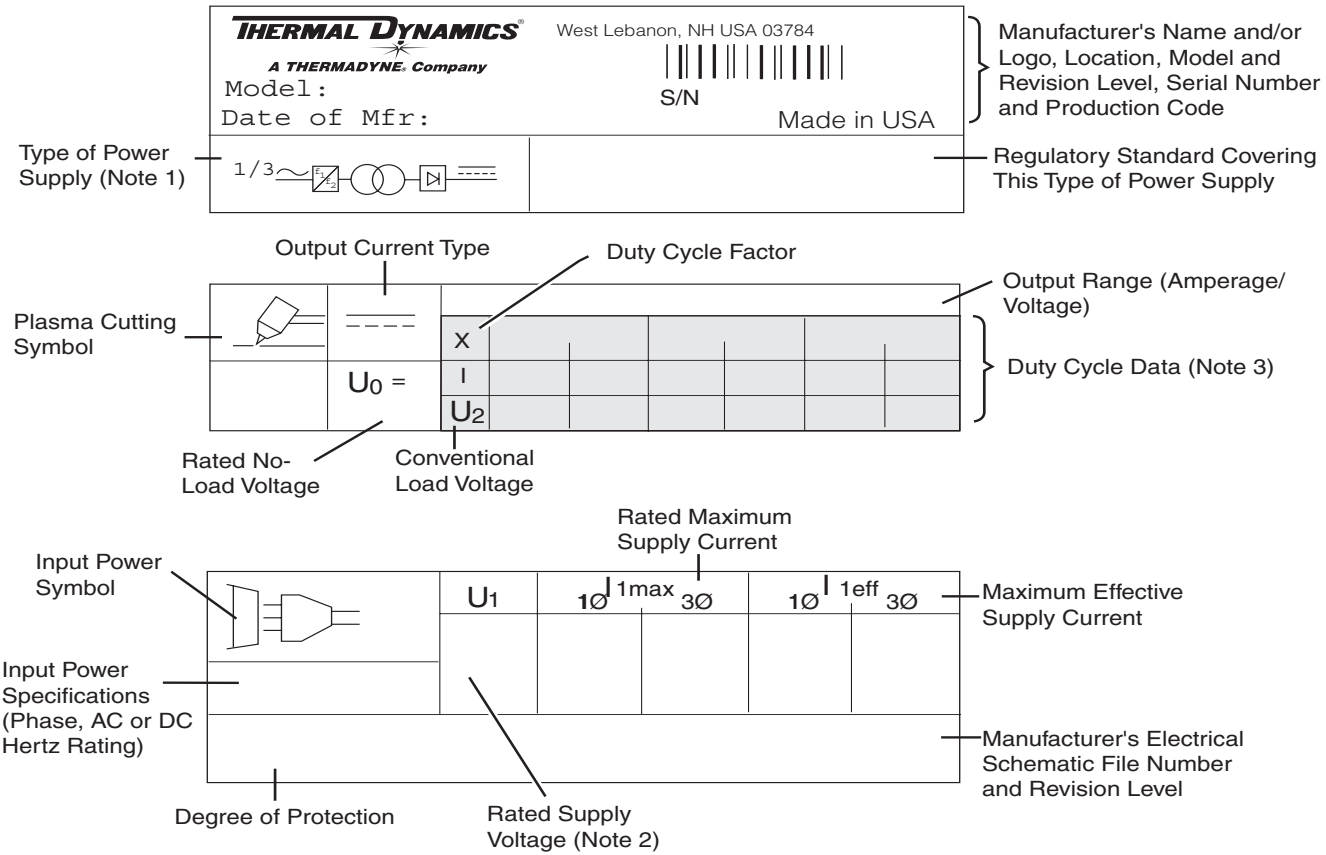

NOTES:

1. Symbol shown indicates single- or three-phase AC input, static frequency converter-transformer-rectifier, DC output.
2. Indicates input voltages for this power supply. Most power supplies carry a label at the input power cord showing input voltage requirements for the power supply as built.
3. Top row: Duty cycle values.
IEC duty cycle value is calculated as specified by the International ElectroTechnical Commission.
TDC duty cycle value is determined under the power supply manufacturer's test procedures.
Second row: Rated cutting current values.
Third row: Conventional load voltage values.
4. Sections of the Data Tag may be applied to separate areas of the power supply.

Standard Symbols

- ~ AC
- DC
- ∅ Phase

Art # A-03288

APPENDIX 3: TORCH PIN - OUT DIAGRAMS

A. Hand Torch Pin - Out Diagram

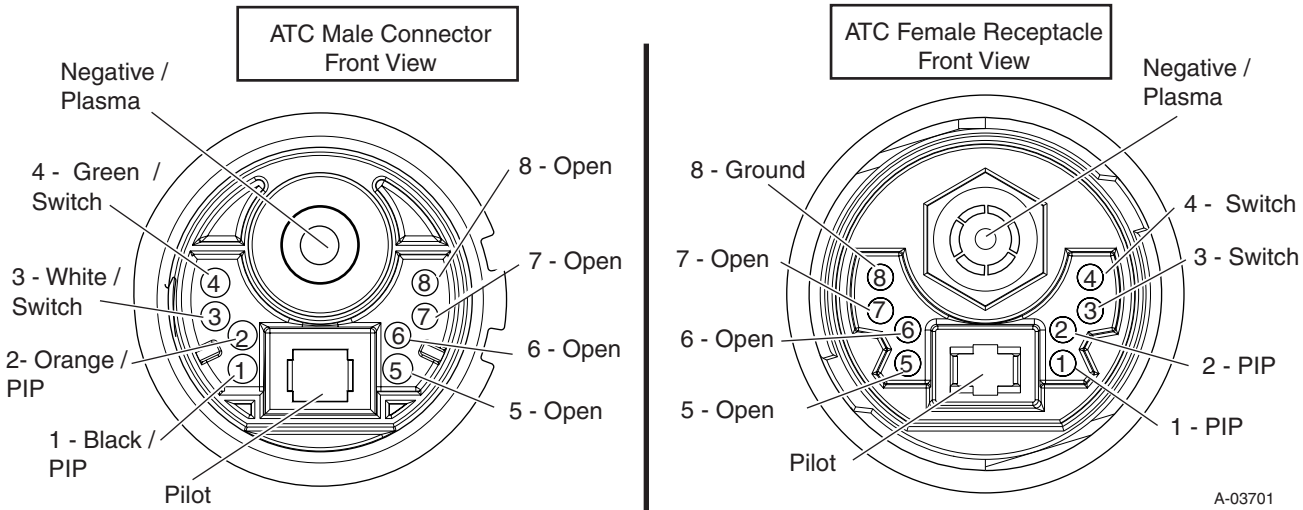

B. Mechanized (Machine) Torch Pin - Out Diagram

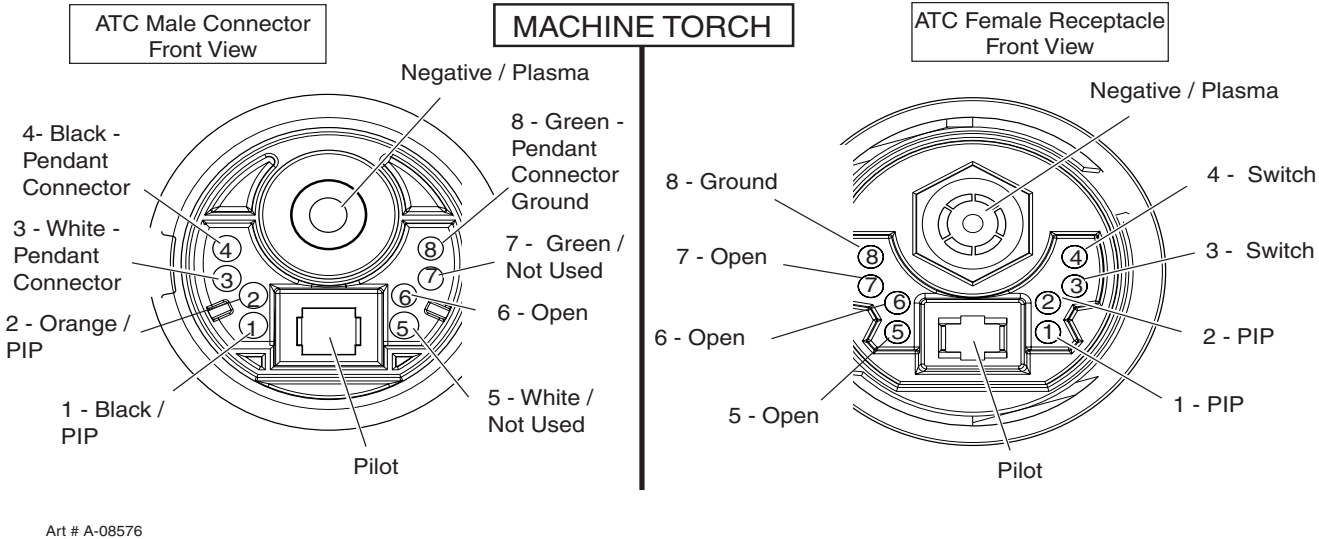

C. Automation (Machine) Torch Pin - Out Diagram

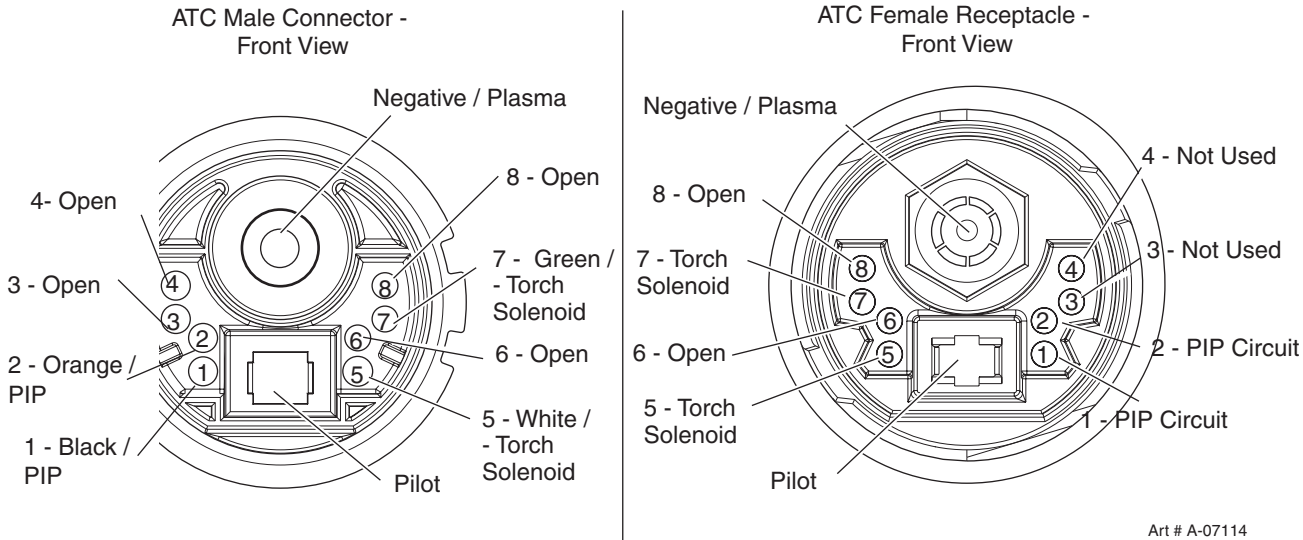

APPENDIX 4: TORCH CONNECTION DIAGRAMS

A. Hand Torch Connection Diagram

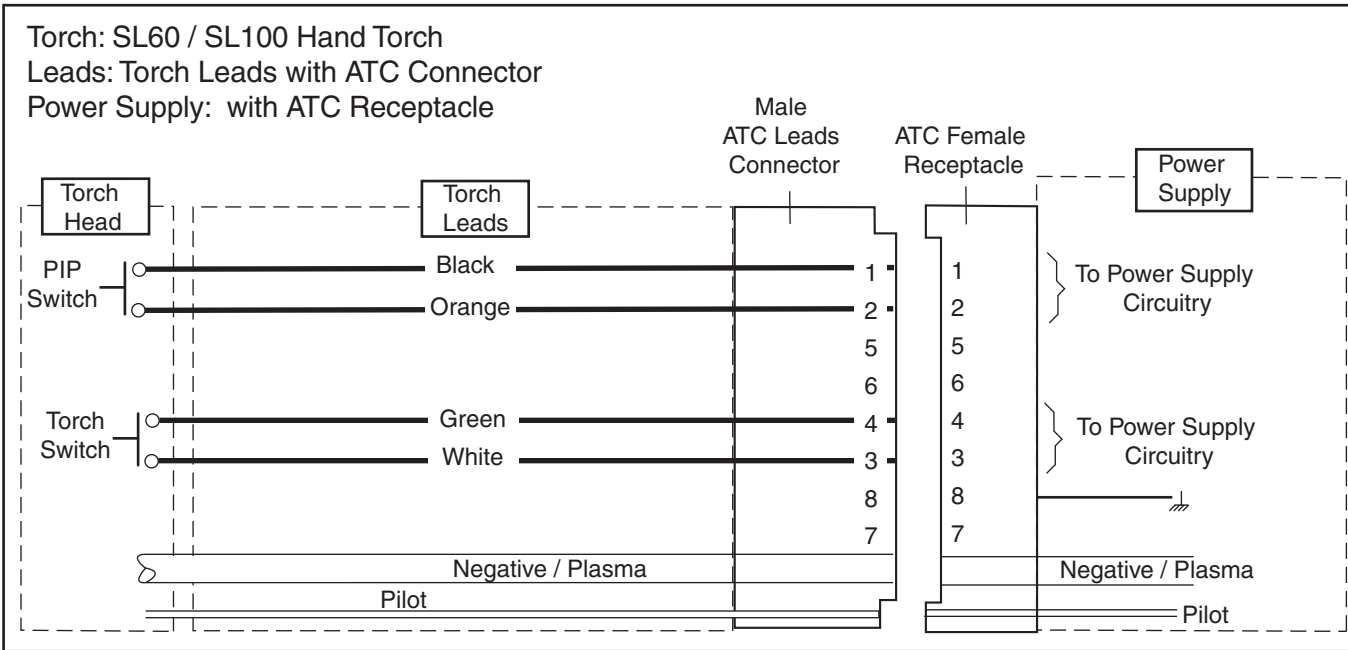

Art # A-03797

B. Mechanized Torch Connection Diagram

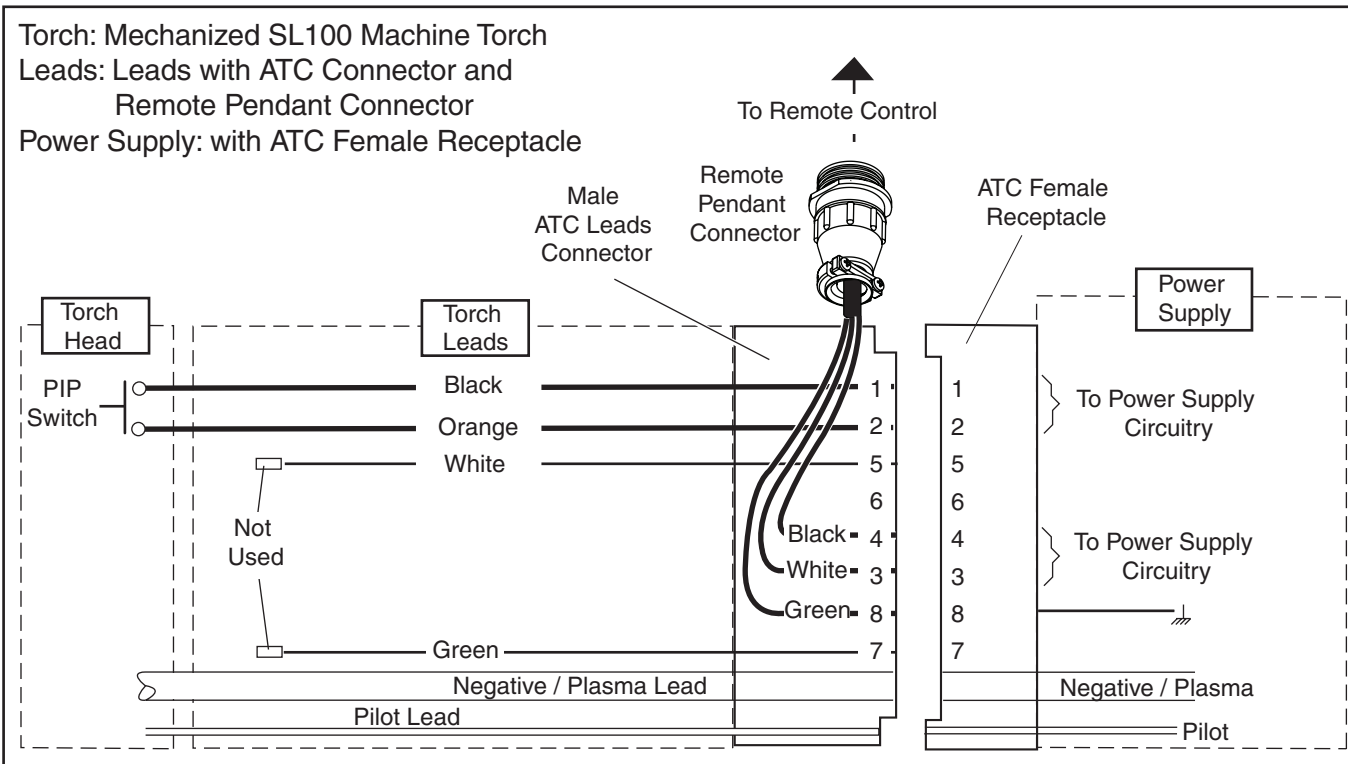

Art # A-08577

C. Automation Torch Connection Diagram

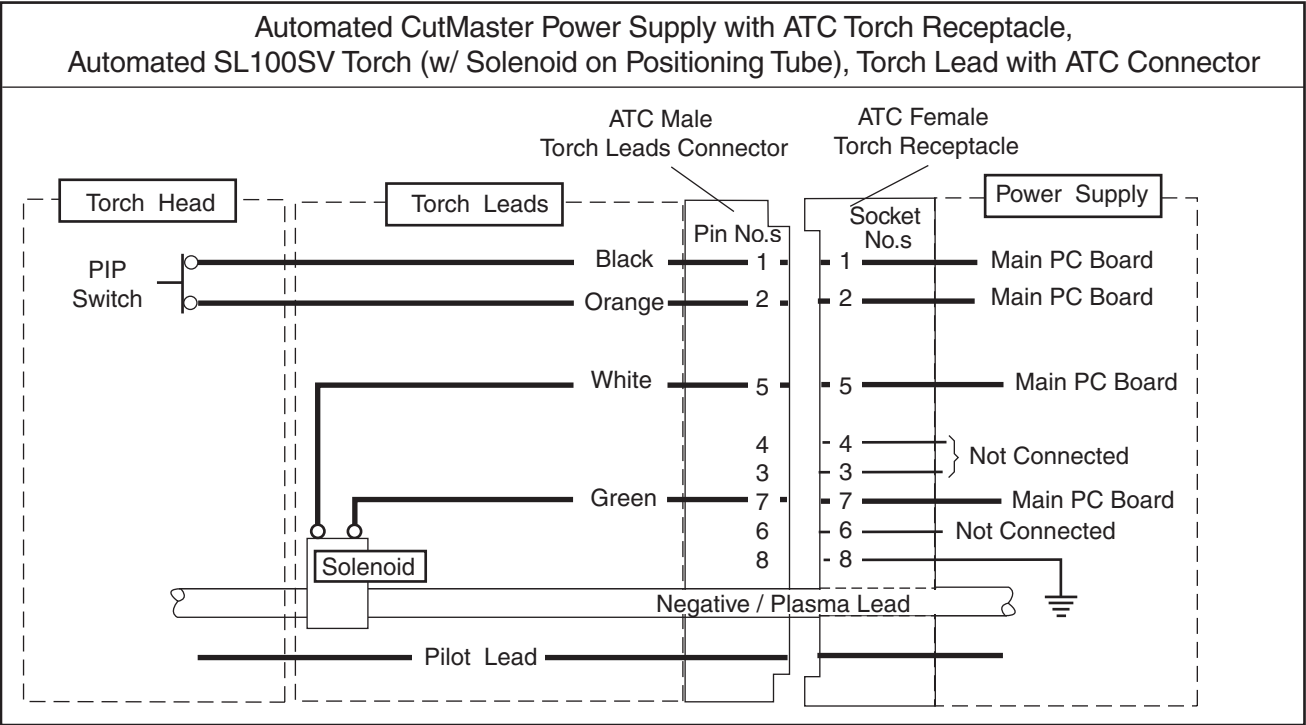

Art # A-07115

APPENDIX 5: SYSTEM SCHEMATIC, 380/400/415V UNITS

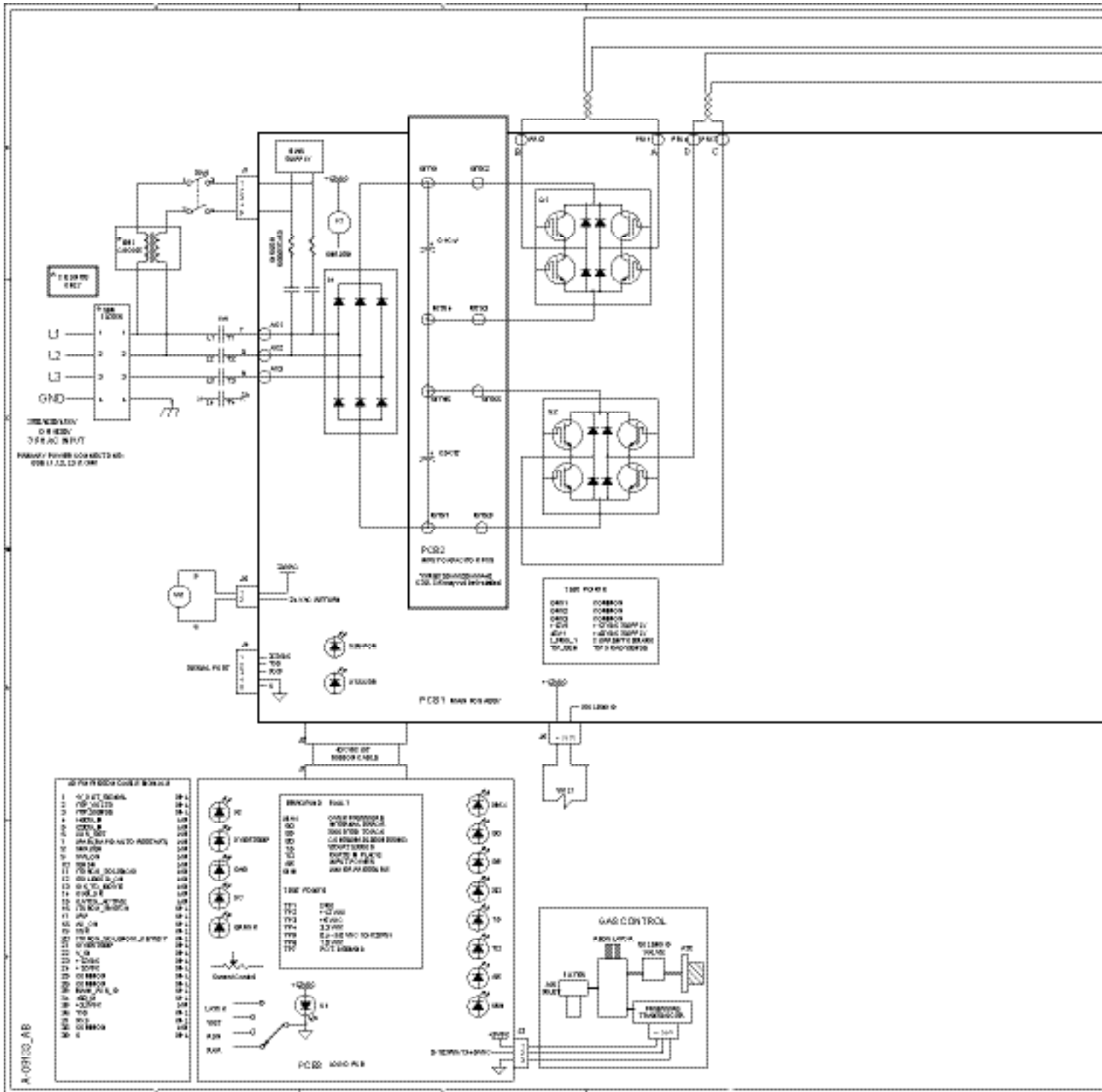

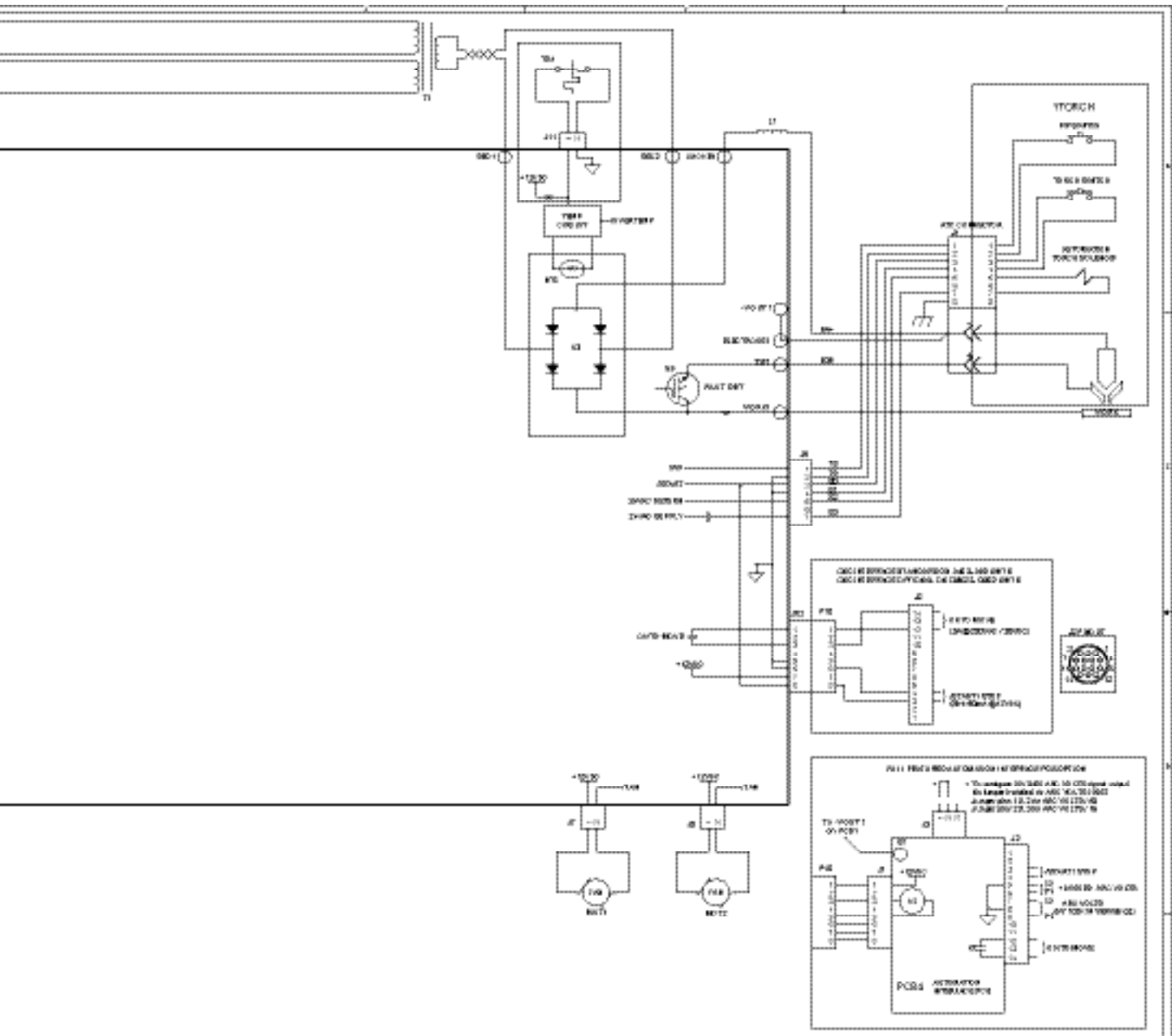

A-09130_A8

REV	DATE	BY	CHK	APP	DESCRIPTION
1	04/20/04	JK	JK	JK	INITIAL DESIGN
2	05/10/04	JK	JK	JK	REVISED TO INCLUDE TOUCH SCREEN
3	05/10/04	JK	JK	JK	REVISED TO INCLUDE TOUCH SCREEN 2
4	05/10/04	JK	JK	JK	REVISED TO INCLUDE TOUCH SCREEN 2
5	05/10/04	JK	JK	JK	REVISED TO INCLUDE TOUCH SCREEN 2
6	05/10/04	JK	JK	JK	REVISED TO INCLUDE TOUCH SCREEN 2
7	05/10/04	JK	JK	JK	REVISED TO INCLUDE TOUCH SCREEN 2
8	05/10/04	JK	JK	JK	REVISED TO INCLUDE TOUCH SCREEN 2
9	05/10/04	JK	JK	JK	REVISED TO INCLUDE TOUCH SCREEN 2
10	05/10/04	JK	JK	JK	REVISED TO INCLUDE TOUCH SCREEN 2
11	05/10/04	JK	JK	JK	REVISED TO INCLUDE TOUCH SCREEN 2
12	05/10/04	JK	JK	JK	REVISED TO INCLUDE TOUCH SCREEN 2
13	05/10/04	JK	JK	JK	REVISED TO INCLUDE TOUCH SCREEN 2
14	05/10/04	JK	JK	JK	REVISED TO INCLUDE TOUCH SCREEN 2
15	05/10/04	JK	JK	JK	REVISED TO INCLUDE TOUCH SCREEN 2
16	05/10/04	JK	JK	JK	REVISED TO INCLUDE TOUCH SCREEN 2
17	05/10/04	JK	JK	JK	REVISED TO INCLUDE TOUCH SCREEN 2
18	05/10/04	JK	JK	JK	REVISED TO INCLUDE TOUCH SCREEN 2
19	05/10/04	JK	JK	JK	REVISED TO INCLUDE TOUCH SCREEN 2
20	05/10/04	JK	JK	JK	REVISED TO INCLUDE TOUCH SCREEN 2
21	05/10/04	JK	JK	JK	REVISED TO INCLUDE TOUCH SCREEN 2
22	05/10/04	JK	JK	JK	REVISED TO INCLUDE TOUCH SCREEN 2
23	05/10/04	JK	JK	JK	REVISED TO INCLUDE TOUCH SCREEN 2
24	05/10/04	JK	JK	JK	REVISED TO INCLUDE TOUCH SCREEN 2
25	05/10/04	JK	JK	JK	REVISED TO INCLUDE TOUCH SCREEN 2
26	05/10/04	JK	JK	JK	REVISED TO INCLUDE TOUCH SCREEN 2
27	05/10/04	JK	JK	JK	REVISED TO INCLUDE TOUCH SCREEN 2
28	05/10/04	JK	JK	JK	REVISED TO INCLUDE TOUCH SCREEN 2
29	05/10/04	JK	JK	JK	REVISED TO INCLUDE TOUCH SCREEN 2
30	05/10/04	JK	JK	JK	REVISED TO INCLUDE TOUCH SCREEN 2

HERMAL DYNAMICS

1800 Sycamore Street
GaitHERMAL
Littleton, Colorado 80120

A SCHEMATIC COMPANY

© 2004 Hermal Dynamics
All rights reserved.

PCB ASSEMBLY

A-09130_A8

REV 10/1/04

C 4211329

APPENDIX 6: Publication History

Cover Date	Rev.	Change(s)
Jan 9, 2009	AA	Manual released.
May 29, 2009	AB	Updated 400V/600V schematic in appendix per ECOB1399



GLOBAL CUSTOMER SERVICE CONTACT

Thermadyne USA

2800 Airport Road
Denton, Tx 76207 USA
Telephone: (940) 566-2000
800-426-1888
Fax: 800-535-0557

Thermadyne Canada

2070 Wyecroft Road
Oakville, Ontario
Canada, L6L5V6
Telephone: (905)-827-1111
Fax: 905-827-3648

Thermadyne Europe

Europe Building
Chorley North Industrial Park
Chorley, Lancashire
England, PR6 7Bx
Telephone: 44-1257-261755
Fax: 44-1257-224800

Thermadyne, China

RM 102A
685 Ding Xi Rd
Chang Ning District
Shanghai, PR, 200052
Telephone: 86-21-69171135
Fax: 86-21-69171139

Thermadyne Asia Sdn Bhd

Lot 151, Jalan Industri 3/5A
Rawang Integrated Industrial Park - Jln Batu Arang
48000 Rawang Selangor Darul Ehsan
West Malaysia
Telephone: 603+ 6092 2988
Fax : 603+ 6092 1085

Cigweld, Australia

71 Gower Street
Preston, Victoria
Australia, 3072
Telephone: 61-3-9474-7400
Fax: 61-3-9474-7510

Thermadyne Italy

OCIM, S.r.L.
Via Benaco, 3
20098 S. Giuliano
Milan, Italy
Tel: (39) 0236546801
Fax: (39) 0236546840

Thermadyne International

2070 Wyecroft Road
Oakville, Ontario
Canada, L6L5V6
Telephone: (905)-827-9777
Fax: 905-827-9797

Corporate Headquarters
16052 Swingley Ridge Road
Suite 300
St. Louis, MO 63017
Telephone: 636-728-3000
Email: TDCSales@Thermadyne.com
www.thermadyne.com

